

GRINDERS



DIE GRINDERS

For smaller surface applications and/or precision material removal, collet type grinders are preferred for deburring, die countouring, light chamfering.

WHEEL GRINDERS ANGLE AND VERTICAL GRINDERS

For medium and large surfaces, wheel grinders are designed for grinding, cutting, countouring at a high material removal rate.

For maximum material removal with minimum effort, choose the best tool.

STEP 1

Applications

- ▶ Materials
- ▶ Access
- ▶ Intensity
- ▶ Precision

STEP 2

Abrasives

- ▶ Carbide burrs
- ▶ Mounted points
- ▶ Grinding wheels
- ▶ Cutting wheels
- ▶ Flap wheels

STEP 3

Tools

- ▶ Die grinders
- ▶ Angle grinders
- ▶ Vertical grinders
- ▶ Extended shaft grinders

DIE GRINDERS / STRAIGHT WHEEL GRINDERS

ANGLE GRINDERS / VERTICAL GRINDERS

SUPER INDUSTRIAL



CP3000 SERIES
CP3019 - CP3109 - CP3119
CP3249 - CP3550

CP3019 - CP3109
CP3650 - CP3850
CP3349 - CP3T30

INDUSTRIAL MAINTENANCE
AND PRODUCTION



CP9104Q
CP3030 - CP9113
CP3451

CP3040 - CP3450 - CP857
CP3550 - CP3750 - CP3330 - CP3340
CP75 SERIES

GENERAL MAINTENANCE



CP875
CP876 - CP860
CP74 SERIES

CP7500
CP854
CP91 SERIES

Caution: The selected grinder speed should not be higher than Maximum Operating Speed recommended by abrasive manufacturers

ERGONOMIC FEATURES

Chicago Pneumatic Abrasive Tools are designed with advanced ergonomics and features required to enable operators to achieve increased productivity levels:

- Significant sound and vibration reduction - helps reduce operator fatigue and improve performance.
- Complete line - designed for maximum productivity under rugged conditions.
- Wide choice of tools - die grinders, small wheel grinders, horizontal grinders, and vertical grinders.
- Powerful yet lightweight - produces more power per pound than comparable electric models.

- Air powered - Minimal risk of electrical shock or overheating - even with continuous use.

OTHER FEATURES:

- Rugged construction - to withstand tough use.
- Heat treated internal parts - keep tool operating, minimize repairs.
- Engineered to minimize downtime - simple replacement of rotor blades usually restores original power.
- Wide variety of accessories - Increases productivity, ergonomics, and safety.

COLLET GRINDERS

Recommended speeds depend on both the shank and head diameter of the carbide burr.

The choice of burr depends on the size of your application. A larger volume of material to be removed will require a larger size abrasive. Select the tool rpm depending on the diameter of the burr head, the material to be ground and the material in the rotary burr. Use tungsten carbide burrs for hard and tough materials. High speed steel burrs are recommended for unhardened and medium hard materials. See table.

MATERIAL TYPE	DIAMETER OF THE HEAD OF THE CARBIDE BURRS				
	1/8" (3 mm)	1/4" (6 mm)	3/8" (10 mm)	1/2" (12 mm)	5/8" (16 mm)
Steel	60,000 - 90,000	45,000 - 60,000	30,000 - 40,000	22,500 - 30,000	18,000 - 24,000
Tempered steel	60,000 - 90,000	30,000 - 45,000	19,000 - 30,000	15,000 - 22,500	12,000 - 18,000
Stainless steel	60,000 - 90,000	30,000 - 45,000	19,000 - 30,000	15,000 - 22,500	12,000 - 18,000
Casting	45,000 - 90,000	22,500 - 60,000	15,000 - 40,000	11,000 - 30,000	9,000 - 24,000
Titanium	60,000 - 90,000	30,000 - 45,000	19,000 - 30,000	15,000 - 22,500	12,000 - 18,000
Nickel	60,000 - 90,000	30,000 - 45,000	19,000 - 30,000	15,000 - 22,500	12,000 - 18,000
Copper & copper alloys	45,000 - 90,000	22,500 - 60,000	15,000 - 40,000	11,000 - 30,000	9,000 - 24,000
Aluminium	30,000 - 90,000	15,000 - 70,000	10,000 - 50,000	7,000 - 3,8000	6,000 - 30,000
Plastics	30,000 - 90,000	15,000 - 70,000	10,000 - 50,000	7,000 - 3,8000	6,000 - 30,000
Cermet	60,000 - 90,000	30,000 - 45,000	19,000 - 30,000	15,000 - 22,500	12,000 - 18,000

Small precision deburring: die grinding is performed with either tungsten carbide, high speed steel burrs or mounted points.



Carbide Burrs

WHEEL GRINDERS

Pure material removal, regardless of whether it is removed from a cramped or an open space, is determined by the power generated on the grinding application. The applied feed force and the rotation of the wheel generates a cutting force which when multiplied by the peripheral speed of the wheel, represents the power for removing material (power = peripheral speed x cutting force).

Chicago Pneumatic grinders features a high degree of safety. Safety throttles, over-speed shut-off and wheel guards are good examples of product safety features carried by your grinders.

The table below will help you to translate the peripheral speed of the grinding wheel to the correct rotational speed of the grinder when using a specific diameter of grinding wheel.

DIAMETER IN. (MM)	MAXIMUM WORK SPEED IN M/S OR FEET/MIN							
	32	35	40	50	63	80	100	125
1 (25)	24,450	26,740	30,560	38,200	48,130	61,120	76,390	95,490
1-1/4 (32)	19,100	20,890	23,870	29,840	37,600	47,750	59,680	74,600
1-9/16 (40)	15,280	16,710	19,100	23,870	30,080	38,200	47,750	59,680
2 (50)	1,220	13370	15,280	19,100	24,060	30,560	38,200	47,750
2-1/2 (63)	9,700	10,610	12,130	15,160	19,100	24,250	30,320	37,890
3 (75)	7,640	8,360	9,550	11,940	15,040	19,100	23,870	29,840
4 (100)	6,110	6,680	7,640	9,550	12,030	15,280	19,100	23,870
5 (125)	4,890	5,350	6,110	7,640	9,630	12,220	15,280	19,100
6 (150)	4,070	4,460	5,090	6,370	8,020	1,190	12,730	15,920
7 (180)	3,400	3,710	4,240	5,310	6,680	8,490	10,610	13,260
7-7/8 (200)	3,060	3,340	3,820	4,780	6,020	7,640	9,550	11,940
9 (230)	2,660	2,910	3,320	5,150	5,230	6,640	8,300	10,380
9-27/32 (250)	2,440	2,670	3,060	3,820	4,810	6,110	7,640	9,550
11-13/16 (300)	2,040	2,230	2,550	3,180	4,010	5,090	6,370	7,960

HOW ENSURE SAFE OPERATION:

- Check the tool free speed
- Match the maximum speed of the abrasive to the grinder
- Inspect the grinding wheel
- Inspect the flange
- Inspect the wheel guard
- Wear protection goggles, gloves & hearing protection
- Test run your grinder in a protected area after assembling the wheel
- Make sure that the tools receive proper maintenance, see service sheet
- Disconnect the tool from the air network before changing accessories abrasives.

Angle Die Grinders

Power capacity < 0.3hp (250W)



22,500 RPM



CP875

COMPACT ANGLE DIE GRINDER FOR TIGHT AREAS

FEATURES AND BENEFITS

- 90° angle head allows flexibility in tight areas
- Compact and lightweight tool designed for easy maneuverability
- Built-in air regulator
- Includes 1/4" and 6 mm collets



23,000 RPM



CP7406

CHANGING A CARBIDE BURR HAS NEVER BEEN EASIER!

FEATURES AND BENEFITS

- Burrs easily changeable allowing the operator to use only one wrench thanks to the new spindle lock system.
- Good surface grip avoiding the tool to slip once in operator's hand thanks to the handle's material (TPR) and ergonomics.
- High application coverage thanks to the multitude of heads (short & long straight, 120°, 90°)
- Less heat transfer between the motor and the sleeve thanks to the composite housing



CP7408

CP7406 with 120° angle

See accessories page 95

MODEL	PART NUMBER	FREE SPEED	POWER		COLLET CAPACITY	AIR CONS. @LOAD		NET WEIGHT		LENGTH		VIBRATION LEVEL ISO 28927 (MS2)	SOUND PRESS.	SOUND POWER	AIR INLET
		rpm	hp	W	in. (mm)	cfm	l/s	lb	kg	in.	mm	a	ISO 15744 - dB(A)	in.	
CP875	T023995	22,500	0.3	220	1/4 (6.4mm)	22	10	0.99	0.45	4.88	124	4.4	101	112	1/4
CP7406	8941074060	23,000	0.3	250	15/64 (6.0mm)	2.1	1	1.32	0.6	6.42	163	5.4	78.1	89.1	1/4
CP7408	8941074080	23,000	0.3	250	15/64 (6.0mm)	2.1	1	1.37	0.62	7.68	195	4.3	78.6	89.6	1/4

All models: Hose int. 3/8" (10 mm) - @90 PSI (@6.3 Bar)

Listed specifications are for reference only. Please check documents in each tool.

Angle Die Grinders



CP3030 SERIES

Power capacity < 0.7hp (500W)

GEARLESS DURABLE DESIGN

In pursuit of durability, the CP3030 Series air die grinders are designed with an efficient gearless construction to increase the interval between maintenance and failure elimination.



FEATURES AND BENEFITS

- Industrial grade durability up to 1,000 hours between maintenance intervals
- Gearless construction for high durability
- Up to 0.7hp (500 W) industrial grade motor and 30,000 rpm for a perfect material removal result
- Compact and composite handle for a great operator comfort

See accessories page 95

MODEL	PART NUMBER	FREE SPEED	POWER	COLLET CAPACITY	AIR CONS. @LOAD	NET WEIGHT	LENGTH	VIBRATION LEVEL ISO 28927 (M/S ²)	SOUND PRESS.	SOUND POWER	AIR INLET				
		rpm	hp	W	in. (mm)	cfm	l/s	lb	kg	in.	mm	a	ISO 15744 - dB(A)	in.	
CP3030-325R	6151604090	25,000	0.4	300	15/64 (6.0mm)	17	8	1.15	0.52	6.06	154	<2.5	79.8	90.8	1/4
CP3030-330R	6151604100	30,000	0.4	300	15/64 (6.0mm)	19	9	1.15	0.52	6.06	154	<2.5	77.1	88.1	1/4
CP3030-418R	6151604130	18,000	0.5	400	15/64 (6.0mm)	21	10	1.84	0.84	6.85	174	<2.5	75.4	86.4	1/4
CP3030-420R	6151604140	20,000	0.5	400	15/64 (6.0mm)	23	11	1.84	0.84	6.85	174	<2.5	76.2	87.2	1/4
CP3030-424R	6151604150	24,000	0.5	400	15/64 (6.0mm)	23	11	1.84	0.84	6.85	174	<2.5	77.5	88.5	1/4
CP3030-520R	6151604200	20,000	0.7	500	15/64 (6.0mm)	29	14	1.87	0.85	6.85	174	<2.5	80	91	1/4

All models: Hose int. 3/8" (10 mm) - @90 PSI (@6.3 Bar)

Listed specifications are for reference only. Please check documents in each tool.

Angle Die Grinders



CP3019 SERIES

Power capacity < 0.5hp (370W)

HIGH PERFORMANCE IN A COMPACT PACKAGE

High performance in a compact industrial Air angle die grinder tool with a powerful 0.5 hp (375 W) motor.



FEATURES AND BENEFITS

- Highest durability in demanding applications, up to 2,000 hours maintenance intervals
- Streamlined safety lever for operator safety
- Powerful 0.5 hp (375 W) governed motor ensures safety
- Compact body with an insulating composite over-housing for operator comfort and superior ergonomics

See accessories page 95

MODEL	PART NUMBER	FREE SPEED	POWER		COLLET CAPACITY	AIR CONS. @LOAD		NET WEIGHT		LENGTH		VIBRATION LEVEL <small>(ISO 28927 (M/S2))</small>	SOUND PRESS.	SOUND POWER	AIR INLET
		rpm	hp	W	in. (mm)	cfm	l/s	lb	kg	in.	mm	a	ISO 15744 - dB(A)	in.	
CP3019-12ACES	6151701470	12,000	0.5	375	15/64 (6.0mm)	6	3	1.34	0.61	9.7	246	3.5	77	88	1/4
CP3019-12ACFE	6151702050	12,000	0.5	375	15/64 (6.0mm)	17	8	1.12	0.51	6.5	166	3.7	78	89	1/4
CP3019-09AC	6151702660	9,000	0.5	375	15/64 (6.0mm)	6	3	1.1	0.5	6.5	166	3.3	76	87	1/4
CP3019-18AC	6151704610	18,000	0.5	375	15/64 (6.0mm)	14	6.5	1.12	0.51	6.5	166	4.1	78	88	1/4
CP3019-12AC	6151604070	12,000	0.5	375	15/64 (6.0mm)	17	8	1.12	0.51	8.5	216	3.7	78	89	1/4
CP3019-20AC	6151604080	20,000	0.5	370	15/64 (6.0mm)	19	9.4	1.12	0.51	8.5	216	4.3	82	93	1/4
CP3019-20ACES	6151701460	20,000	0.5	375	15/64 (6.0mm)	14	6.5	1.34	0.61	9.7	246	5	80	91	1/4
CP3019-20ACFE	6151702060	20,000	0.5	375	15/64 (6.0mm)	14	6.5	1.12	0.51	6.5	166	5	80	91	1/4
CNOMO: NOT FOR NA MARKET															
CP3019-12AC CNOMO	6151604230	12,000	0.5	370	15/64 (6.0mm)	17	8	1.12	0.51	8.5	216	3.7	78	89	1/4
CP3019-12ACES CNOMO	6151700390	12,000	0.5	375	15/64 (6.0mm)	6	3	1.34	0.61	9.7	246	3.5	77	88	1/4
CP3019-20AC CNOMO	6151604240	20,000	0.5	370	15/64 (6.0mm)	19	9.4	1.12	0.51	8.5	216	4.3	82	93	1/4
CP3019-20ACES CNOMO	6151700470	20,000	0.5	375	15/64 (6.0mm)	14	6.5	1.34	0.61	9.7	246	5	80	91	1/4

All models: Hose int. 3/8" (10 mm) - @90 PSI (@6.3 Bar)

Listed specifications are for reference only. Please check documents in each tool.

Angle Die Grinders

Power capacity < 1.5hp (600W)



12,000 RPM



CP3550-120ACC

INDUSTRIAL TOUGH AND EASY TO HANDLE

FEATURES AND BENEFITS

- Industrial grade durability up to 1,000 hours between maintenance intervals
- Streamlined safety lever for operator safety.
- 1.5 hp (1,100 W) governed motor to maintain maximal abrasive speed
- Spindle lock button allows for fast carbide burr replacement to reduce tool downtime



13,000 RPM



CP3109-13AC

HIGHLY DURABLE BEVEL GEAR FOR HIGH PERFORMANCE

FEATURES AND BENEFITS

- Highest durability in demanding applications, up to 2,000 hours maintenance intervals
- Streamlined safety lever for operator safety
- Steel housing with an insulating composite over-housing for operator comfort and superior ergonomics
- Powerful 0.8hp (600 W) governed motor

CP3109-13ACES

Same features as CP3109-13AC in extended shaft version

See accessories page 95

MODEL	PART NUMBER	FREE SPEED	POWER		COLLET CAPACITY	AIR CONS. @LOAD		NET WEIGHT		LENGTH		VIBRATION LEVEL ISO 28927 (M/S ²)	SOUND PRESS.	SOUND POWER	AIR INLET
		rpm	hp	W	in. (mm)	cfm	l/s	lb	kg	in.	mm	a	ISO 15744 - dB(A)	in.	
CP3550-120ACC	6151604420	12000	1.48	1100	1/4 (6.4mm)	55	26	3.31	1.5	9.8	249	6.1	84	95	3/8
CP3109-13AC	6151604060	13000	0.8	600	15/64 (6.0mm)	31	15	2.43	1.1	8.5	216	3.7	85	96	3/8
CP3109-13ACES	6151701360	13000	0.8	600	-	21	10	3.09	-	11.3	287	<2.5	83	-	3/8

All models: Hose int. 3/8" (10 mm) - @90 PSI (@6.3 Bar)

Listed specifications are for reference only. Please check documents in each tool.

Power capacity < 0.1hp (600W)



60,000 RPM



CP9104Q

HIGH-SPEED FOR PRECISION WORK

FEATURES AND BENEFITS

- Very low noise level for greater comfort
- High free speed allows for greater accuracy
- Silencer hose included
- 3 mm and 1/8" collets included
- Lightweight for great maneuverability



60,000 RPM



CP3000-600CR 3 mm

HIGH SPEED, LIGHTWEIGHT AIR PENCIL GRINDER

FEATURES AND BENEFITS

- Steel body for a great durability
- Equipped with rotary valve for smooth power adjustment and grooved housing for an incomparable working precision
- Silencer hose included to reduce noise level
- High free speed, 60,000 rpm, ensures efficiency

CP9104Q Kit

Same features as CP9104Q in kit form.



CP3000-600CR

Same features as CP3000-600CR 3 mm with 1/8" collet for Imperial system only.

See accessories page 95

MODEL	PART NUMBER	FREE SPEED	POWER		COLLET CAPACITY	AIR CONS. @LOAD		NET WEIGHT		LENGTH		VIBRATION LEVEL ISO 28927 (MIS2)	SOUND PRESS.	SOUND POWER	AIR INLET
		rpm	hp	W	in. (mm)	cfm	l/s	lb	kg	in.	mm	a	ISO 15744 - dB(A)	in.	
CP9104Q	6151959104	60000	0.05	40	1/8 (3mm)	6.8	3.2	0.44	0.2	5.24	133	<2.5	71	82	1/4
CP9104Q Kit	6151950104	60000	0.05	40	1/8 (3mm)	6.8	3.2	0.44	0.2	5.24	133	<2.5	71	82	1/4
CP3000-600CR 3mm	6151600330	60000	0.12	90	15/64 (6.0mm)	5.5	2.6	0.31	0.14	6.02	153	<2.5	71	82	1/4
CP3000-600CR	6151600140	60000	0.12	90	15/64 (6.0mm)	5.5	2.6	0.31	0.14	6.02	153	<2.5	71	82	1/4

All models: Hose int. 3/8" (10 mm) - @90 PSI (@6.3 Bar)

Listed specifications are for reference only. Please check documents in each tool.

Straight Die Grinders

Power capacity < 0.5hp (400W)



30,000 RPM



CP876

COMPACT AND LIGHTWEIGHT

FEATURES AND BENEFITS

- Compact and lightweight tool designed for easy maneuverability and ideal for limited space applications
- Front exhaust for better comfort
- Built-in air regulator
- Includes 1/4" and 6 mm collets



27,000 RPM



CP872

ECONOMIC COMPACT TOOL FOR GREAT EFFICIENCY

FEATURES AND BENEFITS

- Aluminum alloy body for better robustness
- Built-in air regulator & CP streamlined safety lever
- Includes 1/4" and 6 mm collets



24,000 RPM



CP860

DURABLE PARTNER FOR GENERAL MAINTENANCE USE

FEATURES AND BENEFITS

- Rugged and energy efficient 0.54 hp (400 W) motor for better productivity
- Adjustable speed regulator & lock-off throttle
- Square handle design for greater comfort

CP860E

Same features as CP860 with 6 mm collet

See accessories page 95

MODEL	PART NUMBER	FREE SPEED		POWER		COLLET CAPACITY		AIR CONS. @LOAD		NET WEIGHT		LENGTH		VIBRATION LEVEL	SOUND PRESS.	SOUND POWER	AIR INLET
		rpm	hp	W	in. (mm)	cfm	l/s	lb	kg	in.	mm	a	ISO 15744 - dB(A)	in.			
CP876	T023996	30,000	0.3	220	15/64 (6.0mm)	23	11	0.75	0.34	4.76	121	<2.5	101.3	112	1/4		
CP872	T025373	27,000	0.63	470	15/64 (6.0mm)	26	12	1.26	0.57	6.5	165	<2.5	100.9	111.9	1/4		
CP860	T019704	24,000	0.5	400	1/4 (6.4mm)	21	9.9	1.26	0.57	5.75	146	3.7	92.5	103.5	1/4		
CP860E	T021136	24,000	0.5	400	1/4 (6.4mm)	21	9.9	1.26	0.57	5.75	146	3.7	92.5	104	1/4		

All models: Hose int. 3/8" (10 mm) - @90 PSI (@6.3 Bar)

Listed specifications are for reference only. Please check documents in each tool.

Power capacity < 0.5hp (400W)



28,000 RPM



CP7405

CP7405

CHANGING A CARBIDE BURR HAS NEVER BEEN EASIER!

FEATURES AND BENEFITS

- Burrs easily changeable allowing the operator to use only one wrench thanks to the new spindle lock system.
- Good surface grip avoiding the tool to slip once in operator's hand thanks to the handle's material (TPR) and ergonomics.
- High application coverage thanks to the multitude of heads (short & long straight, 120°, 90°)
- Less heat transfer between the motor and the sleeve thanks to the composite housing



CP7411

Same features as CP7405 with 22,000 rpm

See accessories page 95

MODEL	PART NUMBER	FREE SPEED	POWER		COLLET CAPACITY	AIR CONS. @LOAD		NET WEIGHT		LENGTH		VIBRATION LEVEL ISO 28927 (M/S ²)	SOUND PRESS.	SOUND POWER	AIR INLET
		rpm	hp	W	in. (mm)	cfm	l/s	lb	kg	in.	mm	a	ISO 15744 - dB(A)	in.	
CP7405	8941074050	28,000	0.3	250	15/64 (6.0mm)	2.1	1	1.1	0.5	6.93	176	3.6	76.2	87.2	1/8
CP7411	8941074110	22,000	0.6	420	15/64 (6.0mm)	3	1.4	1.54	0.7	7.09	180	3.1	80.7	91.7	1/4

All models: Hose int. 3/8" (10 mm) - @90 PSI (@6.3 Bar)

Listed specifications are for reference only. Please check documents in each tool.

Straight Die Grinders



CP3000 SERIES

Power capacity < 0.7hp (500W)

LIGHTWEIGHT AND ERGONOMIC STRAIGHT DIE GRINDERS

CP3000 straight air die grinder is ideal for customers looking for durable, powerful, and comfortable industrial die grinders for polishing, grinding, and deburring applications.



FEATURES AND BENEFITS

- Industrial grade durability up to 1,000 hours between maintenance intervals
- Compact and composite handle for a great operator comfort
- Up to 0.7hp (500 W) industrial grade motor and 30,000 rpm for a perfect material removal result

See accessories page 95

MODEL	PART NUMBER	FREE SPEED	POWER		COLLET CAPACITY	AIR CONS. @LOAD		NET WEIGHT		LENGTH		VIBRATION LEVEL ISO 28927 (M/S ²)	SOUND PRESS.	SOUND POWER	AIR INLET
		rpm	hp	W	in. (mm)	cfm	l/s	lb	kg	in.	mm	a	ISO 15744 - dB(A)	in.	
CP3000-325R	6151600150	25,000	0.4	300	15/64 (6.0mm)	19	9	0.87	0.4	5.91	150	3.2	79.1	90.1	1/4
CP3000-330R	6151600160	30,000	0.4	300	15/64 (6.0mm)	19	9	0.87	0.4	5.91	150	<2.5	77.6	88.6	1/4
CP3000-325F	6151600180	25,000	0.4	300	15/64 (6.0mm)	17	8.1	0.87	0.4	5.91	150	<2.5	84	95	1/4
CP3000-415R	6151600190	15,000	0.5	400	15/64 (6.0mm)	21	10	1.69	0.77	7.72	196	<2.5	80.3	91.3	1/4
CP3000-418R	6151600200	18,000	0.5	400	15/64 (6.0mm)	21	10	1.69	0.77	7.72	196	<2.5	77.1	88.1	1/4
CP3000-420R	6151600210	20,000	0.5	400	15/64 (6.0mm)	23	11	1.69	0.77	7.72	196	<2.5	78.1	89.1	1/4
CP3000-424R	6151600220	24,000	0.5	400	15/64 (6.0mm)	23	11	1.69	0.77	7.72	196	<2.5	79.3	90.3	1/4
CP3000-420F	6151600250	20,000	0.5	400	15/64 (6.0mm)	22	10	1.69	0.77	7.72	196	<2.5	82	93	1/4
CP3000-515R	6151600270	15,000	0.7	500	15/64 (6.0mm)	25	12	1.88	0.86	7.68	195	<2.5	80.7	91.7	1/4
CP3000-518R	6151600280	18,000	0.7	500	15/64 (6.0mm)	27	13	1.88	0.86	7.68	195	<2.5	79.5	90.5	1/4
CP3000-520R	6151600290	20,000	0.7	500	15/64 (6.0mm)	27	13	1.88	0.86	7.68	195	<2.5	80.6	91.6	1/4

All models: Hose int. 3/8" (10 mm) - @90 PSI (@6.3 Bar)

Listed specifications are for reference only. Please check documents in each tool.

Straight Die Grinders



CP9113G

Power capacity 1hp (750W)

ROBUST STEEL CONSTRUCTION

Enjoy the benefits of this extremely reliable and durable 1 HP (750 W) straight die grinder, designed with rugged steel construction for tough applications.



FEATURES AND BENEFITS

- Machined steel housing for a robust construction.
- Front exhaust to eliminate dust and to give better visibility
- Up to 1 hp (750 W) industrial grade motor and 25,000 rpm for a perfect material removal result

See accessories page 95

MODEL	PART NUMBER	FREE SPEED		POWER		COLLET CAPACITY		AIR CONS. @LOAD		NET WEIGHT		LENGTH		VIBRATION LEVEL ISO 28927 (M/S2)	SOUND PRESS.	SOUND POWER	AIR INLET
		rpm	hp	W	in. (mm)	cfm	l/s	lb	kg	in.	mm	a	ISO 15744 - dB(A)	in.			
CP9113G	6151600010	25,000	1	750	1/4 (6.4mm)	31	15	2.54	1.15	6.69	170	3.6	92.9	103.9	3/8		

All models: Hose int. 3/8" (10 mm) - @90 PSI (@6.3 Bar)

Listed specifications are for reference only. Please check documents in each tool.

Straight Die Grinders



CP3550-180

Power capacity 1.5hp (1100W)

INDUSTRIAL TOUGH AND EASY TO HANDLE

Ergonomic Angle die grinder designed with an extremely durable bevel gear and governed 1.5 hp (1100 W) motor for your industrial grinding applications.



FEATURES AND BENEFITS

- Industrial grade durability up to 1,000 hours between maintenance intervals
- Streamlined safety lever for operator safety.
- 1.5 hp (1,100 W) governed motor to maintain maximal abrasive speed
- Spindle lock button allows for fast carbide burr replacement to reduce tool downtime

See accessories page 95

MODEL	PART NUMBER	FREE SPEED	POWER		COLLET CAPACITY	AIR CONS. @LOAD		NET WEIGHT		LENGTH		VIBRATION LEVEL ISO 22827 (M/S ²)	SOUND PRESS.	SOUND POWER	AIR INLET
		rpm	hp	W	in. (mm)	cfm	l/s	lb	kg	in.	mm	a	ISO 15744 - dB(A)	in.	
CP3550-120	6151600620	12,000	1.5	1100	15/64 (6.0mm)	55	26	2.65	1.2	9.76	248	<2.5	78	89	3/8
CP3550-180	6151600630	18,000	1.5	1100	15/64 (6.0mm)	55	26	2.65	1.2	9.76	248	3.5	80	91	3/8

All models: Hose int. 3/8" (10 mm) - @90 PSI (@6.3 Bar)

Listed specifications are for reference only. Please check documents in each tool.

Straight Die Grinders



CP3019 SERIES

Power capacity < 0.5 hp (375 W)

HIGH PERFORMANCE IN A COMPACT PACKAGE

High performance in a compact industrial Air angle die grinder tool with a powerful 0.5 hp (375 W) motor.



FEATURES AND BENEFITS

- Highest durability in demanding applications, up to 2,000 hours maintenance intervals
- Streamlined safety lever for operator safety
- Powerful 0.5 hp (375 W) governed motor ensures safety
- Compact body with an insulating composite over-housing for operator comfort and superior ergonomics

See accessories page 95

MODEL	PART NUMBER	FREE SPEED		POWER		COLLET CAPACITY		AIR CONS. @LOAD		NET WEIGHT		LENGTH		VIBRATION LEVEL ISO 28927 (MISZ)	SOUND PRESS.	SOUND POWER	AIR INLET
		rpm	hp	W	in. (mm)	cfm	l/s	lb	kg	in.	mm	a	ISO 15744 - dB(A)	in.			
CP3019-18	6151600090	18,000	0.5	370	1/4 (6.4mm)	15	7.1	0.84	0.38	6.65	169	<2.5	75.8	86.8	1/4		
CP3019-20	6151600100	20,000	0.5	370	1/4 (6.4mm)	19	9	0.84	0.38	6.65	169	4.1	74.7	85.7	1/4		
CP3019-25	6151600110	25,000	0.5	370	1/4 (6.4mm)	19	9	0.84	0.38	6.65	169	2.6	77.7	88.7	1/4		
CP3019-31	6151600120	31,000	0.5	370	1/4 (6.4mm)	21	10	0.84	0.38	6.65	169	3.3	79.3	90.3	1/4		
CP3019-40	6151600130	40,000	0.5	370	1/4 (6.4mm)	22	10	0.84	0.38	6.65	169	<2.5	81.2	92.2	1/4		
CNOMO: NOT FOR NA MARKET																	
CP3019-20 CNOMO	6151600340	20,000	0.5	370	1/4 (6.4mm)	19	9	0.84	0.38	6.65	169	<2,5	74	85	1/4		
CP3019-25 CNOMO	6151600350	25,000	0.5	370	1/4 (6.4mm)	19	9	0.84	0.38	6.65	169	<2,5	78	89	1/4		
CP3019-31 CNOMO	6151600360	31,000	0.5	370	1/4 (6.4mm)	21	10	0.84	0.38	6.65	169	2.8	77	88	1/4		
CP3019-40 CNOMO	6151600370	40,000	0.5	370	1/4 (6.4mm)	22	10	0.84	0.38	6.65	169	2.8	77	88	1/4		

All models: Hose int. 3/8" (10 mm) - @90 PSI (@6.3 Bar)

Listed specifications are for reference only. Please check documents in each tool.

Straight Die Grinders



CP3109 SERIES

Power capacity < 0.8 hp (600 W)

HIGHLY DURABLE BEVEL GEAR FOR HIGH PERFORMANCE

High durability in a high productivity industrial straight die Grinder tool with a powerful 0.85 hp (600 W) motor.



FEATURES AND BENEFITS

- Highest durability in demanding applications, up to 2,000 hours maintenance intervals
- Streamlined safety lever for operator safety
- Steel housing with an insulating composite over-housing for operator comfort and superior ergonomics
- Powerful 0.8hp (600 W) governed motor

See accessories page 95

MODEL	PART NUMBER	FREE SPEED		POWER		COLLET CAPACITY		AIR CONS. @LOAD		NET WEIGHT		LENGTH		VIBRATION LEVEL ISO 28927 (M/S ²)	SOUND PRESS.	SOUND POWER	AIR INLET
		rpm	hp	W	in. (mm)	cfm	l/s	lb	kg	in.	mm	a	ISO 15744 - dB(A)	in.			
CP3109-15	6151701630	15,000	0.8	600	1/4 (6.4mm)	31	15	1.98	0.9	8.74	222	3.4	74	85	3/8		
CP3109-19	6151600020	19,000	0.8	600	1/4 (6.4mm)	31	15	1.98	0.9	8.74	222	3.1	76	87	3/8		
CP3109-24	6151600030	24,000	0.8	600	1/4 (6.4mm)	31	15	1.98	0.9	8.74	222	<2.5	81	92	3/8		
CP3109-24RT	6151702900	24,000	0.8	600	1/4 (6.4mm)	31	15	2.64	1.2	8.74	222	4.97	82	93	3/8		
CP3109-28	6151600040	28,000	0.8	600	1/4 (6.4mm)	31	15	1.98	0.9	8.74	222	<2.5	85	96	3/8		
CNOMO: NOT FOR NA MARKET																	
CP3109-15 CNOMO	6151701230	15,000	0.8	600	15/64 (6.0mm)	31	15	1.98	0.9	8.74	222	<2.5	74	85	3/8		
CP3109-19 CNOMO	6151701240	19,000	0.8	600	15/64 (6.0mm)	31	15	1.98	0.9	8.74	222	<2.5	74	85	3/8		
CP3109-24 CNOMO	6151701250	24,000	0.8	600	15/64 (6.0mm)	31	15	1.98	0.9	8.74	222	<2.5	82	93	3/8		
CP3109-28 CNOMO	6151701260	28,000	0.8	600	15/64 (6.0mm)	31	15	1.98	0.9	8.74	222	4.6	85	96	3/8		

All models: Hose int. 3/8" (10 mm) - @90 PSI (@6.3 Bar)

Listed specifications are for reference only. Please check documents in each tool.

Straight Die Grinders



CP3119 SERIES

Power capacity < 1.2 hp (900 W)

STRAIGHT DIE GRINDER FOR HIGH PERFORMANCE

A complete line of Air straight die grinders with a 1.2 hp (900 W) motor, including short and long reach, designed for high performance in high productivity industrial grinding applications.



FEATURES AND BENEFITS



- Highest durability in demanding applications, up to 2,000 hours maintenance intervals
- Streamlined safety lever for operator safety
- Steel housing with an insulating composite over-housing for operator comfort and superior ergonomics
- Powerful 0.8hp (600 W) governed motor

See accessories page 95

MODEL	PART NUMBER	FREE SPEED	POWER	COLLET CAPACITY	AIR CONS. @LOAD	NET WEIGHT	LENGTH	VIBRATION LEVEL ISO 28927 (MISZ)	SOUND PRESS.	SOUND POWER	AIR INLET				
		rpm	hp	W	in. (mm)	cfm	l/s	lb	kg	in.	mm	a	ISO 15744 - dB(A)	in.	
CP3119-010	6151701680	1,000	1.2	900	1/4 (6.4mm)	36	17	3.09	1.4	8.74	222	3.8	81	92	3/8
CP3119-12	6151600050	12,000	1.2	900	1/4 (6.4mm)	33	16	2.2	1	8.74	222	<2.5	76	71	3/8
CP3119-15	6151600060	15,000	1.2	900	1/4 (6.4mm)	36	17	2.2	1	8.74	222	3.8	81	92	3/8
CP3119-18	6151600070	18,000	1.2	900	1/4 (6.4mm)	38	18	2.2	1	8.74	222	2.9	80	91	3/8
CP3119-22	6151600080	22,000	1.2	900	1/4 (6.4mm)	38	18	2.2	1	8.74	222	<2.5	81	92	3/8
CP3119-035	6151701670	3,500	1.2	900	1/4 (6.4mm)	38	18	3.09	1.4	8.74	222	<2.5	81	92	3/8
CP3119-060	6151701660	5,500	1.2	900	1/4 (6.4mm)	36	17	3.09	1.4	14.21	361	<2.5	81	92	3/8
CNOMO: NOT FOR NA MARKET															
CP3119-010 CNOMO	6151701200	1,000	1.2	900	15/64 (6.0mm)	33	16	3.09	1.4	8.74	222	<2.5	76	87	3/8
CP3119-12 CNOMO	6151600380	12,000	1.2	900	15/64 (6.0mm)	33	16	2.2	1	8.74	222	<2.5	75	86	3/8
CP3119-15 CNOMO	6151600390	15,000	1.2	900	15/64 (6.0mm)	36	17	2.2	1	8.74	222	<2.5	80	92	3/8
CP3119-18 CNOMO	6151600400	18,000	1.2	900	15/64 (6.0mm)	38	18	2.2	1	8.74	222	<2.5	81	92	3/8
CP3119-22 CNOMO	6151600410	22,000	1.2	900	15/64 (6.0mm)	38	18	2.2	1	8.74	222	<2.5	81	92	3/8
CP3119-035 CNOMO	6151701210	3,500	1.2	900	15/64 (6.0mm)	33	16	3.09	1.4	8.74	222	2.9	80	91	3/8
CP3119-060 CNOMO	6151701220	5,500	1.2	900	15/64 (6.0mm)	33	16	3.09	1.4	14.21	361	<2.5	76	87	3/8

All models: Hose int. 3/8" (10 mm) - @90 PSI (@6.3 Bar)

Listed specifications are for reference only. Please check documents in each tool.

Die Grinders

Die Grinders

Extended Shaft straight die grinders.
Power capacity < 0.6hp (420W)



27,000 RPM



CP7410

CHANGING A CARBIDE BURR HAS NEVER BEEN EASIER!

FEATURES AND BENEFITS

- Burrs easily changeable allowing the operator to use only one wrench thanks to the new spindle lock system.
- Good surface grip avoiding the tool to slip once in operator's hand thanks to the handle's material (TPR) and ergonomics.
- High application coverage thanks to the multitude of heads (short & long straight, 120°, 90°)
- Less heat transfer between the motor and the sleeve thanks to the composite housing



CP7412

Same features as CP7410 with 22,000 rpm



24,000 RPM



CP860ES

DURABLE PARTNER FOR GENERAL MAINTENANCE USE

FEATURES AND BENEFITS

- Rugged and energy efficient 0.54 hp (400 W) motor for better productivity
- Adjustable speed regulator & lock-off throttle
- Square handle design for greater comfort

CP860ESE

Same features as CP860ES with 6 mm collet

See accessories page 95

MODEL	PART NUMBER	FREE SPEED	POWER	COLLET CAPACITY		AIR CONS. @LOAD		NET WEIGHT		LENGTH		VIBRATION LEVEL ISO 28927 (M/S2)	SOUND PRESS.	SOUND POWER	AIR INLET
		rpm	hp	W	in. (mm)	cfm	l/s	lb	kg	in.	mm	a	ISO 15744 - dB(A)	in.	
CP7410	8941074100	27,000	0.3	250	15/64 (6.0mm)	2.1	1	1.43	0.65	9.76	248	4.9	76.1	87.1	1/4
CP7412	8941074120	22,000	0.6	420	15/64 (6.0mm)	3	1.4	2.43	1.1	12.99	330	2.6	80.4	91.4	1/4
CP860ES	T023193	24,000	0.5	400	1/4 (6.4mm)	23	10	2.09	0.95	11.57	294	3.7	92.6	103.5	1/4
CP860ESE	T023354	24,000	0.5	400	1/4 (6.4mm)	23	10	2.09	0.95	11.57	294	3.7	93	103.6	1/4

All models: Hose int. 3/8" (10 mm) - @90 PSI (@6.3 Bar)

Listed specifications are for reference only. Please check documents in each tool.

Extended shaft straight die grinders. Power capacity < 1hp (750W)



25,000 RPM



CP9113GES

ROBUST STEEL CONSTRUCTION

FEATURES AND BENEFITS

- Machined steel housing for a robust construction.
- Front exhaust to eliminate dust and to give better visibility
- Up to 1 hp (750 W) industrial grade motor and 25,000 rpm for a perfect material removal result



18,000 RPM



CP3451-18SEC

INDUSTRIAL GRADE EXTENDED SHAFT DIE GRINDER

FEATURES AND BENEFITS

- Industrial grade durability up to 1,000 hours between maintenance intervals
- Machined aluminum housing for a lightweight easy to use Die Grinder.
- Streamlined safety lever
- 1 hp (750 W) industrial grade motor and 25,000 rpm for a perfect material removal result
- Superior ergonomics with 2-handed handling

See accessories page 95

MODEL	PART NUMBER	FREE SPEED		POWER		COLLET CAPACITY		AIR CONS. @LOAD		NET WEIGHT		LENGTH		VIBRATION LEVEL ISO 28927 (MIS2)	SOUND PRESS.	SOUND POWER	AIR INLET
		rpm	hp	W	in. (mm)	cfm	l/s	lb	kg	in.	mm	a	ISO 15744 - dB(A)	in.			
CP9113GES	6151602070	25,000	1	750	1/4 (6.4mm)	31	15	3.57	1.62	12.6	320	2.7	82.5	93.5	3/8		
CP3451-18SEC	6151602010	18,000	1	750	15/64 (6.0mm)	36	17	3.09	1.4	12.99	330	2.7	83.8	94.8	3/8		

All models: Hose int. 3/8" (10 mm) - @90 PSI (@6.3 Bar)

Listed specifications are for reference only. Please check documents in each tool.

Extended Shaft Straight Die Grinders



18,000 RPM

CP3550-180ES

Power capacity 1.5hp (1100W)

INDUSTRIAL TOUGH AND EASY TO HANDLE

Ergonomic Angle die grinder designed with an extremely durable bevel gear and governed 1.5 hp (1100 W) motor for your industrial grinding applications.



FEATURES AND BENEFITS

- Industrial grade durability up to 1,000 hours between maintenance intervals
- Streamlined safety lever for operator safety.
- 1.5 hp (1,100 W) governed motor to maintain maximal abrasive speed
- Spindle lock button allows for fast carbide burr replacement to reduce tool downtime

CP3550-120ES

Same features as CP3550-180ES with 12,000 RPM

See accessories page 95

MODEL	PART NUMBER	FREE SPEED	POWER		COLLET CAPACITY	AIR CONS. @LOAD		NET WEIGHT		LENGTH		VIBRATION LEVEL ISO 22827 (M/S ²)	SOUND PRESS.	SOUND POWER	AIR INLET
		rpm	hp	W	in. (mm)	cfm	l/s	lb	kg	in.	mm	a	ISO 15744 - dB(A)	in.	
CP3550-120ES	6151602350	12000	1.5	1100	15/64 (6.0mm)	55	26	3.09	1.4	14.37	365	<2.5	77	88	3/8
CP3550-180ES	6151602360	18000	1.5	1100	15/64 (6.0mm)	55	26	3.09	1.4	14.37	365	<2.5	81	92	3/8

All models: Hose int. 3/8" (10 mm) - @90 PSI (@6.3 Bar)

Listed specifications are for reference only. Please check documents in each tool.

Extended Shaft Straight Die Grinders



CP3019ES SERIES

Power capacity < 0.5 hp (370W)

STRAIGHT COMPACT DESIGN FOR HIGH PERFORMANCE

High performance in a compact industrial Air straight or straight extended die grinder tool with a powerful 0.5 hp (375 W) motor.



FEATURES AND BENEFITS

- Highest durability in demanding applications, up to 2,000 hours maintenance intervals
- Streamlined safety lever for operator safety
- Powerful 0.5 hp (375 W) governed motor ensures safety
- Compact body with an insulating composite over-housing for operator comfort and superior ergonomics

See accessories page 95

MODEL	PART NUMBER	FREE SPEED		POWER		COLLET CAPACITY		AIR CONS. @LOAD		NET WEIGHT		LENGTH		VIBRATION LEVEL ISO 28927 (M/S ²)	SOUND PRESS.	SOUND POWER	AIR INLET
		rpm	hp	W	in. (mm)	cfm	l/s	lb	kg	in.	mm	a	ISO 15744 - dB(A)	in.			
CP3019-20ES	6151602170	20,000	0.5	370	1/4 (6.4mm)	18	8.5	1.26	0.57	9.8	249	3.7	73.8	84.8	1/4		
CP3019-25ES	6151602180	25,000	0.5	370	1/4 (6.4mm)	19	9	1.26	0.57	9.8	249	3.2	76.9	87.9	1/4		
CP3019-31ES	6151602190	31,000	0.5	370	1/4 (6.4mm)	19	9.4	1.26	0.57	9.8	249	3.6	80.7	91.7	1/4		
CP3019-40ES	6151602200	40,000	0.5	370	1/4 (6.4mm)	21	10	1.26	0.57	9.8	249	3	80.3	91.3	1/4		
CNOMO: NOT FOR NA MARKET																	
CP3019-20ES CNOMO	6151602210	20,000	0.5	370	1/4 (6.4mm)	18	8.5	1.26	0.57	9.8	249	2.9	75	86	1/4		
CP3019-25ES CNOMO	6151602220	25,000	0.5	370	1/4 (6.4mm)	19	9	1.26	0.57	9.8	249	4.7	78	89	1/4		
CP3019-31ES CNOMO	6151602230	31,000	0.5	370	1/4 (6.4mm)	19	9.4	1.26	0.57	9.8	249	<2,5	80	91	1/4		
CP3019-40ES CNOMO	6151602240	40,000	0.5	370	1/4 (6.4mm)	21	10	1.26	0.57	9.8	249	<2,5	78	89	1/4		

All models: Hose int. 3/8" (10 mm) - @90 PSI (@6.3 Bar)

Listed specifications are for reference only. Please check documents in each tool.

Extended Shaft Straight Die Grinders



CP3109 SERIES

Power capacity < 0.8 hp (600W)

HIGHLY DURABLE BEVEL GEAR FOR HIGH PERFORMANCE

High durability in a high productivity industrial straight die Grinder tool with a powerful 0.85 hp (600 W) motor.



FEATURES AND BENEFITS

- Highest durability in demanding applications, up to 2,000 hours maintenance intervals
- Streamlined safety lever for operator safety
- Steel housing with an insulating composite over-housing for operator comfort and superior ergonomics
- Powerful 0.8hp (600 W) governed motor

See accessories page 95

MODEL	PART NUMBER	FREE SPEED		POWER		COLLET CAPACITY	AIR CONS. @LOAD		NET WEIGHT		LENGTH		VIBRATION LEVEL	SOUND PRESS.	SOUND POWER	AIR INLET
		rpm	hp	W	in. (mm)		cfm	l/s	lb	kg	in.	mm	ISO 28927 (M/S2)	ISO 15744 - dB(A)	in.	
CP3109-15ES	6151701550	15,000	0.8	600	1/4 (6.4mm)	31	15	2.87	1.3	14.21	361	2.5	76	87	3/8	
CP3109-19ES	6151602080	19,000	0.8	600	1/4 (6.4mm)	31	15	2.87	1.3	14.29	363	<2.5	76	87	3/8	
CP3109-24ES	6151602090	24,000	0.8	600	1/4 (6.4mm)	31	15	2.87	1.3	14.21	361	<2.5	81	92	3/8	
CP3109-28ES	6151602100	28,000	0.8	600	1/4 (6.4mm)	31	15	2.87	1.3	14.21	361	<2.5	85	96	3/8	
CNOMO: NOT FOR NA MARKET																
CP3109-15ES CNOMO	6151701040	15,000	0.8	600	15/64 (6.0mm)	31	15	2.87	1.3	14.29	363	<2.5	76	87	3/8	
CP3109-19ES CNOMO	6151701050	19,000	0.8	600	15/64 (6.0mm)	31	15	2.87	1.3	14.29	363	<2.5	76	87	3/8	
CP3109-24ES CNOMO	6151701060	24,000	0.8	600	15/64 (6.0mm)	31	15	2.87	1.3	14.29	363	2.6	81	92	3/8	
CP3109-28ES CNOMO	6151701070	28,000	0.8	600	15/64 (6.0mm)	31	15	2.87	1.3	14.29	363	<2.5	85	96	3/8	

All models: Hose int. 3/8" (10 mm) - @90 PSI (@6.3 Bar)

Listed specifications are for reference only. Please check documents in each tool.

Extended Shaft Straight Die Grinders



18,000 RPM

CP3119ES SERIES

Power capacity < 1.2 hp (900W)

STRAIGHT DIE GRINDER FOR HIGH PERFORMANCE

A complete line of Air straight die grinders with a 1.2 hp (900 W) motor, including short and long reach, designed for high performance in high productivity industrial grinding applications.



FEATURES AND BENEFITS

- Highest durability in demanding applications, up to 2,000 hours maintenance intervals
- Streamlined safety lever for operator safety
- Available with extended body with one-piece steel structure for high resistance
- Powerful 1.2 hp (900 W) governed motor
- Steel housing with an insulating composite over-housing for operator comfort and superior ergonomics

See accessories page 95

MODEL	PART NUMBER	FREE SPEED		POWER		COLLET CAPACITY		AIR CONS. @LOAD		NET WEIGHT		LENGTH		VIBRATION LEVEL ISO 28927 (M/S ²)	SOUND PRESS.	SOUND POWER	AIR INLET
		rpm	hp	W	in. (mm)	cfm	l/s	lb	kg	in.	mm	a	ISO 15744 - dB(A)	in.			
CP3119-12ES	6151602110	12,000	1.2	900	1/4 (6.4mm)	33	16	3.09	1.4	14.21	361	<2.5	76	87	3/8		
CP3119-15ES	6151602120	15,000	1.2	900	1/4 (6.4mm)	36	17	3.09	1.4	14.21	361	<2.5	81	92	3/8		
CP3119-18ES	6151602130	18,000	1.2	900	1/4 (6.4mm)	38	18	3.09	1.4	14.21	361	<2.5	80	91	3/8		
CP3119-22ES	6151602140	22,000	1.2	900	1/4 (6.4mm)	38	18	3.09	1.4	14.21	361	2.6	81	92	3/8		
CNOMO: NOT FOR NA MARKET																	
CP3119-12ES CNOMO	6151602250	12,000	1.2	900	15/64 (6.0mm)	33	16	3.09	1.4	14.29	363	<2.5	76	87	3/8		
CP3119-15ES CNOMO	6151602260	15,000	1.2	900	15/64 (6.0mm)	36	17	3.09	1.4	14.29	363	<2.5	81	92	3/8		
CP3119-18ES CNOMO	6151602270	18,000	1.2	900	15/64 (6.0mm)	38	18	3.09	1.4	14.29	363	<2.5	80	91	3/8		
CP3119-22ES CNOMO	6151602280	22,000	1.2	900	15/64 (6.0mm)	38	18	3.09	1.4	14.29	363	<2.5	81	92	3/8		

All models: Hose int. 3/8" (10 mm) - @90 PSI (@6.3 Bar)

Listed specifications are for reference only. Please check documents in each tool.

L&XL Extended Shaft Straight Die grinders



CP3119-12EXL

Power capacity < 1.2hp (900W)

STRAIGHT DIE GRINDER FOR HIGH PERFORMANCE

A complete line of Air straight die grinders with a 1.2 hp (900 W) motor, including short and long reach, designed for high performance in high productivity industrial grinding applications.

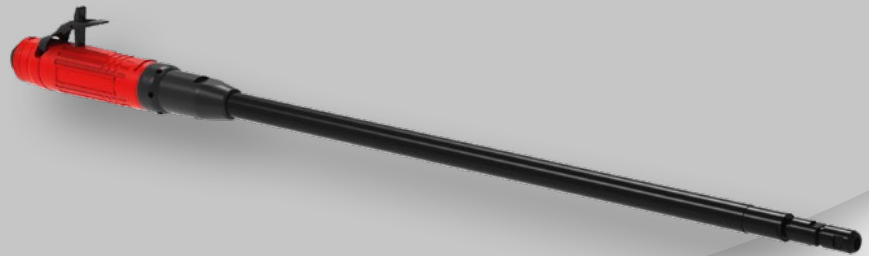

CP3119-12EL

Same feature as CP3119-12EXL with 603 mm extended body

FEATURES AND BENEFITS

- Highest durability in demanding applications, up to 2,000 hours maintenance intervals
- Streamlined safety lever for operator safety
- Available with extended body with one-piece steel structure for high resistance
- Powerful 1.2 hp (900 W) governed motor
- Steel housing with an insulating composite over-housing for operator comfort and superior ergonomics

See accessories page 95



















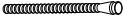



















MODEL	PART NUMBER	FREE SPEED	POWER		COLLET CAPACITY	AIR CONS. @LOAD		NET WEIGHT		LENGTH		VIBRATION LEVEL ISO 28927 (M/S ²)	SOUND PRESS.	SOUND POWER	AIR INLET
		rpm	hp	W	in. (mm)	cfm	l/s	lb	kg	in.	mm	a	ISO 15744 - dB(A)	in.	
CP3119-12EL	6151602150	12,000	1.2	900	1/4 (6.4mm)	33	16	4.63	2.1	23.74	603	<2.5	74	85	3/8
CP3119-12EXL	6151602160	12,000	1.2	900	1/4 (6.4mm)	33	16	5.95	2.7	33.58	853	3	74	72	3/8
CNOMO: NOT FOR NA MARKET															
CP3119-12EL CNOMO	6151701080	12,000	1.2	900	15/64 (6.0mm)	33	16	4.63	2.1	23.74	603	<2.5	74	85	3/8
CP3119-12EXL CNOMO	6151701090	12,000	1.2	900	15/64 (6.0mm)	33	16	5.95	2.7	33.58	853	<2.5	74	86	3/8

All models: Hose int. 3/8" (10 mm) - @90 PSI (@6.3 Bar)

Listed specifications are for reference only. Please check documents in each tool.

Die Grinders Accessories

ACCESSORIES INCLUDED

	MODEL	DESCRIPTION	PART NUMBER
	CP3000-600CR	Collet Ø 1/8"	2050548553
		Wrench	2050548083
	CP3000-600CR	Collet Ø 3 mm	2050548563
		Wrench	2050548083
	CP3000-3..R/F	Serie 300 collet Ø 1/4" (5,55 to 6,35 mm)	6155260590
		Flat wrench (2)	2050548063
	CP3000-5..R - CP3000-4..R/F - CP3030-4..R - CP3030-5..R	Serie 200 collet Ø 1/4" (5,55 to 6,35 mm)	6155260630
		Flat wrench (2)	2050548193
	CP3019-... - CP3019-...ES - CP3019-...AC - CP3119-...	Serie 300 collet Ø 1/4" (5,55 to 6,35 mm)	6155260590
		Exhaust hose L=31" (0,81 m)	6158751060
		Flat wrench 7/16" (11 mm)	6158010030
		Flat wrench 3/4" (19 mm)	6158010760
	CP3019-...CNOMO / CP3019-...ES CNOMO	CNOMO collet Ø 6 mm	6155260460
		Exhaust hose L=31" (0,81 m)	6158750160
		Flat wrench 24/64" (10 mm)	6158010020
		Flat wrench 7/16" (11 mm)	6158010030
	CP3030-3..R	Serie 300 collet Ø 1/4" (5,55 to 6,35 mm)	6155260590
		Flat wrench (2)	2050548063
	CP9113..	Serie 200 collet Ø 1/4" (5,55 to 6,35 mm)	6155260630
		Flat wrench	2050544513
		Flat wrench	2050544523
	CP3451	Serie 200 collet Ø 1/4" (5,55 to 6,35 mm)	6155260630
		Exhaust hose (only with CP3451-18SERC)	6154320110
		Cone wheel adaptor	6155421330
		Stem	6158010810
	CP3109-13AC	Serie 300 collet Ø 1/4" (5,55 to 6,35 mm)	6155260590
		Exhaust hose 60" (1,5 m)	6158751130
		Flat wrench 14 mm	6158010050
		Flat wrench 3/4" (19 mm)	6158010760
	"CP3109-... / CP3109-...ES / CP3119-... / CP3119-...ES	Serie 200 collet Ø 1/4" (5,55 to 6,35 mm)	6155260630
		Exhaust hose 60" (1,5 m)	6158751130
		Flat wrench 14 mm	6158010050
		Flat wrench 3/4" (19 mm)	6158010760
	CP3119-...CNOMO / CP3119-...ES CNOMO	Collet holder extension L=28 mm (1,1")	6155230180
		CNOMO collet Ø 6 mm	6155260490
		Exhaust hose 60" (1,5 m)	6158751130
		Flat wrench 14 mm	6158010050
		Exhaust hose L= 60" (1,5 m)	6158751130
	CP3119-12EL / CP3119-12EXL	Air hose nipple for 3/8" ID hose	6157040170
		Flat wrench 14 mm	6158010050
		Flat wrench 3/4" (19 mm)	6158010760
	CP3550-120/CP3550-180 (ES)	Collet 1/4"	6155260630
		Collet holder	6155260860
		Exhaust Kit	6153995110
		Spanner	2050496453
	CP3650-120/CP3650-180 (ES)	Exhaust Hose Kit	6153995230
		Collet 1/4"	6155260630
		Collet 3 mm	2050484292
		Collet 1/4"	2050484293
	CP7405/CP7406/CP7408/CP7410/CP7411/CP7412	Spanner 11&17MM	2050484423
	CP875/CP876	Collet 1/4"	C138727
		Collet 6 mm	C139289
		Wrench-Spanner	CA144807
	CP860/CP860E/CP860ES/860ESE	Collet 1/4"(CP860 & CP860ES)	C138727
		Collet 6 mm (CP860ES & CP860ESE)	C139289
		Collet 3 mm	2050486503
	CP9104Q	Collet 1/8"	2050507873
		Collet holder kit	8940168862
		Spanner	2050486553

Die Grinders Accessories

OPTIONAL ACCESSORIES

COLLET

SERIES 200 COLLET

TOOL'S MODEL	COLLET CAPACITY	ACCESSORY'S PART NUMBER
CP3000-5..R/F	Collet Ø 3,2 to 4 mm	6155261510
CP3000-4..R/F	Collet Ø 3,7 to 4,5 mm	6155261520
CP3030-4..R	Collet Ø 5,2 to 6 mm	6155260620
CP3030-5..R	Collet Ø 1/4" (5,55 to 6,35 mm)	6155260630
CP3109-..	Collet Ø 7,2 to 8 mm	6155260640
CP3119-.. CP3451-..	Collet Ø 3/8" (8,7 to 9,5 mm)	6155260650
CP9113G/ P9113GES	Collet Ø 1/4" (5,55 to 6,35 mm)	6155260630

TOOL'S MODEL	COLLET CAPACITY	ACCESSORY'S PART NUMBER
 CP875/CP876	3 mm	2050484292
	6 mm	2050484293
	1/4"	C139289
	1/8"	2050516623
	1/4"	C138727

SILENCERS

TOOL'S MODEL	ACCESSORY'S DESCRIPTION	ACCESSORY'S PART NUMBER
3119-...CNOMO	Collet holder extension L=28 mm (1.1")	6155230180
3119-...ES CNOMO	CNOMO collet Ø 3 mm	6155260480
	CNOMO collet Ø 6.35 mm (1/4")	6155260500
	CNOMO collet Ø 8 mm	6155260510
	Complete silencer kit	6153961660
	Reinforced cloth-lined exhaust	6158751160
	Clippable silencer	6153966550

TOOL'S MODEL	COLLET CAPACITY	ACCESSORY'S PART NUMBER
CP3019-..(ES)	Kit silencer	6153961010
CP3000-3..R	Clippable silencer	6153961240
CP3000-..R		
CP3019-..		
CP3030-..R		





SERIES 300 COLLET

TOOL'S MODEL	COLLET CAPACITY	ACCESSORY'S PART NUMBER
CP3000-3..R/F	Collet Ø 1/8" (2,4 to 3,2 mm)	6155260610
CP3019-..(ES)	Collet Ø 4,2 to 5 mm	6155261530
CP3019-..	Collet Ø 3/64" (0,4 to 1,2 mm)	6155260520
CP3109-13AC	Collet Ø 5/64" (1,2 to 2 mm)	6155260530
CP3030-3..R/F	Collet Ø 3/32" (1,7 to 2,5 mm)	6155260540
	Collet Ø 1/8" (2,4 to 3,2 mm)	6155260550
	Collet Ø 5/32" (3,16 to 3,96 mm)	6155260560
	Collet Ø 3/16" (3,95 to 4,75 mm)	6155260570
	Collet Ø 7/32" (4,75 to 5,55 mm)	6155260580
	Collet Ø 1/4" (5,55 to 6,35 mm)	6155260590

ADAPTER

ACCESSORIES DESCRIPTION	ACCESSORY'S PART NUMBER
 Collet adaptor allows use 1/8" shank burrs with any 1/4" collet Die grinder	C123029

TOOL'S MODEL	ACCESSORY'S DESCRIPTION	ACCESSORY'S PART NUMBER
3019-...CNOMO	CNOMO collet Ø 2.5 mm	6155260890
3019-...ES CNOMO	CNOMO collet Ø 3 mm	6155260440
	CNOMO collet Ø 3.2 mm (1/8")	6155260450
	CNOMO collet Ø 4 mm (5/32")	6155260900
	CNOMO collet Ø 5 mm	6155260920
	CNOMO collet Ø 6.4 mm (1/4")	6155260470
	Complete silencer kit	6153961010
	Clippable silencer	6153961240
	Grease gun (capacity 24 g. - 0.8 oz)	6159901490
	Grease for bevel gear (1kg. - 2.2lb.)	6159901480

TOOL'S MODEL	ITEM	COLLET CAPACITY	ACCESSORY'S PART NUMBER
CP3109-..	1	Kit silencer	6153961660
CP3119-..		Clippable silencer	6153966550
CP3109-13AC	2		
CP3650-120AC			
	3	Kit silencer 	6155740760
CP3541	4	Exhaust hose 	6154320110
	5	Exhaust hose adaptor* 	6157301870

* Needed to fit 3 and 4 on safety lever versions

OTHER ACCESSORIES

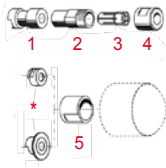

TOOLS MODEL	ITEM	COLLET CAPACITY	ACCESSORY'S PART NUMBER
CP3119-..	1	Spacer for collet holder	6156661490
	2	Series 200 collet holder	6155230230
	3	Series 200 collet	see page 96
	4	Series 200 collet nut	6156071440
	5	Spacer for threaded cone wheel 3/8"	6155035160

CARBIDE BURR

SPEED GUIDE

Recommended Operating speeds. All rpm rating in the table below are listed as thousand

BURR HEAD DIAMETER	MAX OPERATING SPEED	ALUMINUM, PLASTIC		BRASS, COPPER, CAST IRON, BRONZE		UNHARDENED STEEL		HARDENED STEEL, STAINLESS STEEL, NIMONIC ALLOYS	
		Speed Range	Recomm. Start Point	Speed Range	Recomm. Start Point	Speed Range	Recomm. Start Point	Speed Range	Recomm. Start Point
3 mm (1/8")	100	60-80	65	45-80	65	60-80	80	60-80	80
6 mm (1/4")	65	15-60	40	22-60	45	45-60	50	30-45	40
10 mm (3/8")	55	10-50	25	15-40	30	30-40	30	19-30	25
12 mm (1/2")	35	7-30	20	11-30	25	22-30	25	15-22	20
16 mm (5/8")	25	6-20	15	9-20	20	18-20	20	12-18	15
20 mm (3/4")	20	5-21	10	8-17	12	15-17	15	10-15	10
25 mm (1")	15	4-13	8	6-13	10	10-13	10	7-11	8

Recommended speeds are based on standard shank length of 45 mm / (1-3/4") max overhang of 10 mm (3/8")
Maximum recommended operating speeds for extended length shanks is 15,000 rpm

Chicago Pneumatic offers a wide range of products that will cover virtually every application on industry.

CP OFFERS THREE DIFFERENT TYPES OF CUT



DOUBLE CUT

The most common on the market, to be used on hard metal application



FOUNDRY CUT

When high performance and durability is a must, to be used on hard metal application



ALUMINUM CUT

To be used on all soft metals

BURR SHAPES

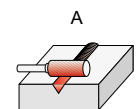

Cylinder w/o endcut

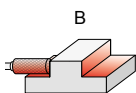

Cylinder with endcut

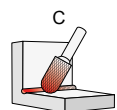

Ball nosed cylinder

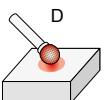

Ball

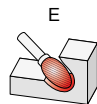

Oval

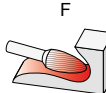

Ball nosed tree

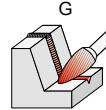

Pointed Tree

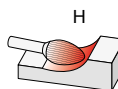

Flame



Ball nose cone

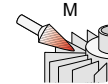

Cone

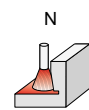

Inverted Cone

Die Grinders Accessories

CARBIDE BURR KITS

DOUBLE CUT



1/8" Ø SHANK

Part No. 8940172240

Kit includes:

- 10 pieces
- 1/8" head for imperial shapes: A, B, C, D, E, F, G, L, M, N



1/4" Ø SHANK

Part No. 8940172242

Kit includes:

- 5 pieces
- 3/8" head; shapes: B, C.
- 1/2" head; shapes: C, F, L



3 mm Ø SHANK

Part No. 8940171785

Kit includes:

- 10 pieces
- 3 mm head for metric shapes: A, B, C, D, E, F, G, L, M, N



6 mm Ø SHANK

Part No. 8940171787

Kit includes:

- 5 pieces
- 10 mm head; shapes: B, C.
- 12 mm head; shapes: C, F, L

POWER CUT



1/4" Ø SHANK

Part No. 8940172241

Kit includes:

- 5 pieces
- 1/2" head for imperial shapes: B, C, F, G, L

ALUMINUM CUT



1/4" Ø SHANK

Part No. 8940172243

Kit includes:

- 5 pieces
- 3/8" head; shapes: B, C.
- 1/2" head; shapes: C, F, L



6 mm Ø SHANK

Part No. 8940171786

Kit includes:

- 5 pieces
- 10 mm head; shapes: B, C.
- 12 mm head; shapes: C, F, L



6 mm Ø SHANK

Part No. 8940171788

Kit includes:

- 5 pieces
- 10 mm head; shapes: B, C.
- 12 mm head; shapes: C, F, L

Straight wheel grinders

Power capacity < 1.2hp (900W)



18000 RPM



CP3451-18SE3

INDUSTRIAL GRADE STRAIGHT WHEEL GRINDER

FEATURES AND BENEFITS

- Industrial grade durability up to 1,000 hours between maintenance intervals
- Machined aluminum housing for a lightweight easy to use straight Grinder
- Streamlined safety lever motor
- Insulating composite over-housing for operator comfort
- Superior ergonomics with 2-handed handling



18000 RPM



CP3119-18ES3

SUPER INDUSTRIAL STRAIGHT WHEEL GRINDER

FEATURES AND BENEFITS

- Highest durability in demanding applications, up to 2,000 hours maintenance intervals
- Streamlined safety lever and 1.2 hp (900 W) governed motor for operator safety
- Long steel housing with an insulating composite over-housing for operator comfort
- Superior ergonomics with 2-handed handling



12000 RPM



CP3119-123X

SUPER INDUSTRIAL STRAIGHT WHEEL GRINDER

FEATURES AND BENEFITS

- Highest durability in demanding applications, up to 2,000 hours maintenance intervals
- Streamlined safety lever and 1.2 hp (900 W) governed motor for operator safety
- Long steel housing with an insulating composite over-housing for operator comfort
- Superior ergonomics with 2-handed handling

See accessories page 95

MODEL	PART NUMBER	FREE SPEED		POWER		MAX WHEEL CAPACITY		SPINDLE THREAD		AIR CONS. @LOAD		NET WEIGHT		LENGTH		VIBRATION LEVEL	SOUND PRESS.	SOUND POWER	AIR INLET
		rpm	hp	W	in.	mm	in.	cfm	l/s	lb	kg	in.	mm	a	ISO 15744 - dB(A)		in.		
CP3119-123X	6151606070	12000	1.2	900	3	80	1/2-13 UNC	33	16	3.75	1.7	9.29	236	<2.5	70	-	3/8		
CP3119-12ES3	6151606010	12000	1.2	900	3	80	3/8-24 UNF	33	16	3.75	1.7	13.31	338	<2.5	81	92	3/8		
CP3119-12ES3X	6151606030	12000	1.2	900	3	80	1/2-13 UNC	33	16	3.75	1.7	13.31	338	<2.5	77	88	3/8		
CP3119-12ES4	6151606020	12000	1.2	900	4	100	3/8-24 UNF	33	16	3.97	1.8	13.31	338	<2.5	78	89	3/8		
CP3119-15ES2	6151606040	15000	1.2	900	2-1/2	63	3/8-24 UNF	33	16	3.53	1.6	13.31	338	<2.5	77	88	3/8		
CP3119-15ES3	6151606050	15000	1.2	900	3	80	3/8-24 UNF	33	16	3.75	1.7	13.31	338	2.7	78	89	3/8		
CP3119-18ES3	6151606060	18000	1.2	900	3	80	3/8-24 UNF	33	16	3.75	1.7	13.31	338	5.3	77	88	3/8		
CP3451-18SE3	6151602030	18000	1	750	3	80	3/8-24 UNF	36	17	3.53	1.6	13.82	351	112	815	94.8	3/8		

All models: Hose int. 3/8" (10 mm) - @90 PSI (@6.3 Bar)

Listed specifications are for reference only. Please check documents in each tool.

Straight wheel grinders

Straight wheel grinders
Power capacity < 3.62hp (2700W)

6000 RPM

**CE CERTIFICATION /
NOT FOR ANSI MARKET**



6000 RPM

**ANSI CERTIFICATION /
NOT FOR CE MARKET**



CP3249-GABSYGE CP3249-GABSYG

HIGH PERFORMANCE IN HEAVY APPLICATIONS

FEATURES AND BENEFITS

- Highest durability in demanding applications with up to 2,000 hours maintenance intervals
- Double ergonomic action safety lever facilitates single-handed engagement and helps reduce risk of accidental start up
- Overspeed prevention device included, ANSI compliant for NA markets, 6" (150 mm) wheel capacity



CP3249 GABSUD

**CE CERTIFICATION /
NOT FOR ANSI MARKET**

CP3249- GABSUDE

Same features as CP3249-GABSYGE
with 4,500 rpm

**ANSI CERTIFICATION /
NOT FOR CE MARKET**

CP3249-GABSUD

Same features as CP3249-GABSYG
with 4,500 rpm

See accessories page 95

	MODEL	PART NUMBER	FREE SPEED	POWER	MAX WHEEL CAPACITY		SPINDLE THREAD	AIR CONS. @LOAD		NET WEIGHT		LENGTH		VIBRATION LEVEL ISO 28927 (M/S2)	SOUND PRESS.	SOUND POWER	AIR INLET	
			rpm	hp	W	in.	mm	in.	cfm	l/s	lb	kg	in.	mm	a	ISO 15744 - dB(A)	in.	
ANSI CE	CP3249-GABSUD	6151606140	4500	3.22	2400	8	200	5/8-11 UNC	69	33	13.8	6.3	21.81	554	< 2.5	82	93	1/2
	CP3249-GABSYG	6151606130	6000	3.62	2700	6	150	5/8-11 UNC	86	41	12.3	5.6	21.81	554	< 2.5	82	93	1/2
	CP3249-GABSUDE	6151606190	4500	3.22	2400	8	200	5/8-11 UNC	69	33	13.8	6.3	19.37	492	< 2.5	82	93	1/2
	CP3249-GABSYGE	6151606180	6000	3.62	2700	6	150	5/8-11 UNC	86	41	12.3	5.6	19.37	492	< 2.5	82	93	1/2

All models: Hose int. 3/8" (10 mm) - @90 PSI (@6.3 Bar)

Listed specifications are for reference only. Please check documents in each tool.

Straight wheel grinders

Accessories

ACCESSORIES INCLUDED

MODEL	DESCRIPTION	PART NUMBER
CP3119-...	Exhaust hose L=31" (0,81 m)	6158751130
CP3119-12ES4	1 4" (100 mm) Disc guard	6155041520
	2 Rear flange 3/8"	6155031310
	3 Front flange 3/8"	6155020630
	4 Locknut	6156080440
CP3119-18ES3 CP3119-15ES3 CP3119-12ES3 CP3119-12ES3X	Flat wrench 9/16" (14,3 mm)	6158010740
	Flat wrench 3/4" (19 mm)	6158010760
	1 3" (80 mm) Disc guard	6155041510
	2 Rear flange 3/8"	6155031250
CP3119-123X	3 Front flange 3/8"	6155020130
	4 Locknut	6156080440
	Flat wrench 9/16" (14,3 mm)	6158010740
	Flat wrench 3/4" (19 mm)	6158010760
CP3119-15ES2	1 3" (80 mm) Disc guard	6155041510
	2 Rear flange 1/2"	6155031270
	3 Front flange 1/2"	6155020440
	4 Locknut	6156080450
CP3451-18SE3	Flat wrench 3/4" (19 mm)	6158010760
	1 2-1/2" (63 mm) DIS GUARD	6155041500
	2 REAR FLANGE 3/8"	6155031260
	3 FRONT FLANGE 3/8"	6155020430
CP3249-GABSUD CP3249-GABSUDE	4 LOCKNUT	6156080440
	FLAT WRENCH 11/16" (17 mm)	6158010320
	FLAT WRENCH 9/16" (14,3 mm)	6158010740
	1 GUARD 3"	6155041910
CP3249-GABSYG CP3249-GABSYGE	2 REAR FLANGE FOR 3"	6155031620
	3 FRONT FLANGE FOR 2.5"	6155020790
	4 NUT	6156080440
	SPANNER FLAT 19MM & 14MM THICK 2,7MM	2050496453
CP3249-GABSYG CP3249-GABSYGE	1 6" (150 mm) DISC GUARD	6155040780
	2 REAR FLANGE	6155030040
	3 FRONT FLANGE	6155020070
	4 LOCKNUT	6156080060
CP3249-GABSYG CP3249-GABSYGE	WOODRUFF KEY 4X7.5X19.5	6156300190
	FLAT WRENCH 1-1/16" (27 mm)	6158010770
	1 6" (150 mm) DISC GUARD	6155040790
	2 REAR FLANGE	6155030280
CP3249-GABSYG CP3249-GABSYGE	3 FRONT FLANGE	6155020270
	4 LOCKNUT	6156080060
	WOODRUFF KEY 4X7.5X19.5	6156300190
	FLAT WRENCH 1-1/16" (27 mm)	6158010770
CP3249-GABSYG CP3249-GABSYGE	1 6" (150 mm) DISC GUARD	6155040790
	2 REAR FLANGE	6155030280
	3 FRONT FLANGE	6155020270
	4 LOCKNUT	6156080060
CP3249-GABSYG CP3249-GABSYGE FLAP WHEEL	WOODRUFF KEY 4X7.5X19.5	6156300190
	FLAT WRENCH 1-1/16" (27 mm)	6158010770
	1 6" (150 mm) DISC GUARD	6155040790
	2 REAR FLANGE	6155030280
CP3249-..	3 FRONT FLANGE	6155020270
	4 LOCKNUT	6156080060
*	Flange supplied with flap wheel. To be drilled to fit the diameter to output shaft of the tool	6156300190
TOOL'S MODEL	COLLET CAPACITY	ACCESSORY'S PART NUMBER
CP3249-..	Kit silencer	6153994600

Angle Grinders

Angle Grinders 2" to 4"
Power capacity < 0.2 hp (370 W)



22,000 RPM



CP7500D

COMPACT CUTTING & GRINDING

FEATURES AND BENEFITS

- Rubber handle grip & side exhaust for better operator comfort
- Lock off safety lever & full 180° protective guard for better security
- High versatility angle grinder, designed for grinding and cutting
- Cut-off tool adapter included



20,000 RPM



CP3019-20A3

HIGH PERFORMANCE & SUSTAINABILITY ARE KEY

FEATURES AND BENEFITS

- Highest durability in demanding applications, up to 2,000 hours maintenance intervals
- Streamlined safety lever
- Governed motor for operator safety
- Compact body with an insulating composite over-housing for operator comfort and superior ergonomics

CP3019-13A4

Same features as CP3019-20A3 with 13,500 rpm and 4" wheel

CP3019-18A3

Same features as CP3019-20A3 with 18,000 rpm

See accessories page 118

MODEL	PART NUMBER	FREE SPEED	AUTO-BALANCER	POWER	MAX WHEEL CAPACITY	SPINDLE THREAD	AIR CONS. @LOAD	NET WEIGHT	LENGTH	VIBRATION LEVEL ISO 28927 (M/S2)	SOUND PRESS.	SOUND POWER	AIR INLET
		rpm		hp W	in. mm	in.	cfm l/s	lb kg	in. mm	a	ISO 15744 - dB(A)		in.
CP7500D	8941075001	22,000	No	0.2 150	2 50	3/8-24 UNF	8 3.8	1.3 0.59	5.51 140	19.9	81	92	1/4
CP3019-13A4	6151607050	13,500	No	0.5 370	4 100	3/8-24 UNF	17 8.3	0.66 0.3	6.42 163	8.6	79.3	90.3	1/4
CP3019-18A3	6151607060	18,000	No	0.5 370	3 75	3/8-24 UNF	19 9.1	0.66 0.3	6.42 163	12.3	80.4	91.4	1/4
CP3019-18AES3	6151700450	18,000	No	0.5 375	3 75	3/8-24 UNF	19 9.1	1.76 0.8	9.56 229	12.3	80	91	1/4
CP3019-20A2	6151704880	20,000	No	0.5 375	2 50	3/8-24 UNF	21 10	1.32 0.6	6.42 163	12.3	78	89	1/4
CP3019-20A3	6151607070	20,000	No	0.5 370	3 75	3/8-24 UNF	19 9	0.66 0.3	6.42 163	13.3	82.6	93.6	1/4
CP3019-20AES2	6151704870	20,000	No	0.5 375	2 50	3/8-24 UNF	21 10	1.76 0.8	9.56 229	12.3	78	89	1/4
CP3019-20AES3	6151700460	20,000	No	0.5 375	3 75	3/8-24 UNF	19 9	1.76 0.8	9.56 229	13.3	83	94	1/4

All models: Hose int. 3/8" (10 mm) - @90 PSI (@6.3 Bar)

Listed specifications are for reference only. Please check documents in each tool.

Angle Grinders 4-1/2" to 5" Power capacity 0.8 hp (600 W)



12,000 RPM



CP9120CR

CP9120CR

LIGHTWEIGHT AND EASY HANDLING

FEATURES AND BENEFITS

- Helical bevel gear design & aluminum alloy housing for high durability
- Keyless adjustable protective guard for better security
- Ergonomic side handle

See accessories page 118

MODEL	PART NUMBER	FREE SPEED	AUTO-BALANCER	POWER	MAX WHEEL CAPACITY	SPINDLE THREAD	AIR CONS. @LOAD	NET WEIGHT	LENGTH	VIBRATION LEVEL ISO 28927 (M/S2)	SOUND PRESS.	SOUND POWER	AIR INLET
		rpm		hp W	in. mm	in.	cfm l/s	lb kg	in. mm	a	ISO 15744 - dB(A)		in.
CP9120CR	6151952120	12,000	No	0.8 600	4 100	3/8-24 UNF	23 11	4.19 1.9	9.17 233	5.3	84	95	1/4
CP9121CR	6151952121	12,000	No	0.8 600	5 125	3/8-24 UNF	25 12	4.63 2.1	9.45 240	11.2	84	95	1/4
CP9122CR	6151952122	12,000	No	0.8 600	4-1/2 115	3/8-24 UNF	29 14	4.19 1.9	9.17 233	5.4	84	95	1/4
CP9121BR	6151957221	12,000	No	0.8 600	5 125	5/8-11 UNC	27 13	4.63 2.1	9.45 240	8.6	84	95	1/4
CP9122BR	6151957222	12,000	No	0.8 600	4-1/2 115	5/8-11 UNC	29 14	4.19 1.9	9.17 233	8.6	84	95	1/4
CP9121AR	6151957321	12,000	No	0.8 600	5 125	M14x2	27 13	4.63 2.1	9.45 240	6.7	84	95	1/4

All models: Hose int. 3/8" (10 mm) - @90 PSI (@6.3 Bar)

Listed specifications are for reference only. Please check documents in each tool.

Angle Grinders

4" to 5"

Power capacity > 0.7 hp (520W)



13,000 RPM



CP854

EFFICIENT AND DURABLE

FEATURES AND BENEFITS

- High performance motor for high efficiency with its 0.6 hp (450 W)
- Helical bevel gear design & aluminum alloy housing for high durability
- 4" (100 mm) wheel capacity



13,500 RPM



CP3040GASTIM

MADE OF STEEL FOR HARSH INDUSTRIAL ENVIRONMENTS

FEATURES AND BENEFITS

- Machined steel housing designed for tough usage
- Super durable bevel gear for a robust construction
- Ultra compact for a great maneuverability in both version standard and extended shaft.
- Up to 0.7 hp (520 W) industrial grade motor and 13,000 rotations per minute for a perfect material removal result.



13,000 RPM



CP3109-13A4

EXTREMELY DURABLE FOR INDUSTRIAL APPLICATIONS

FEATURES AND BENEFITS

- Highest durability in demanding applications, up to 2,000 hours maintenance intervals
- Streamlined safety lever
- Governed motor for operator safety
- Steel housing with an insulating composite over-housing for operator comfort and superior ergonomics
- Standard or extended shaft

CP854E

Same features as CP854 with 5" wheel & M10 spindle thread

CP3040GABTIM

Same features as CP3040-GASTIM with short shaft

CP3109-13A4ES

Same features as CP3109-13A4 with extended shaft

See accessories page 118

MODEL	PART NUMBER	FREE SPEED	AUTO-BALANCER	POWER	MAX WHEEL CAPACITY	SPINDLE THREAD	AIR CONS. @LOAD	NET WEIGHT	LENGTH	VIBRATION LEVEL ISO 28927 (M/S2)	SOUND PRESS.	SOUND POWER	AIR INLET
		rpm		hp	W	in. mm	cfm l/s	lb kg	in. mm	a	ISO 15744 - dB(A)		in.
CP854	T023186	13,000	No	0.7	520	4 100	3/8-24 UNF	24 11	3.75 1.7	9.02 229	4.9	85 96	1/4
CP854E	T023187	12,000	No	0.7	520	5 125	M10	16 7.6	3.75 1.7	9.02 229	4.9	85 96	1/4
CP3040GABTIM	6151607010	13,500	No	1	750	4 100	3/8-24 UNF	26 12	3.31 1.5	8.27 210	7.2	88 99	3/8
CP3040GASTIM	6151607020	13,500	-	1	750	4 100	3/8-24 UNF	26 12	3.75 1.7	10.63 270	9.6	92 103	3/8
CP3109-13A4	6151607030	13,000	No	0.8	600	4 100	3/8-24 UNF	32 15	2.65 1.2	8.54 217	9.3	85 96	3/8
CP3109-13A4ES	6151607040	13,000	No	0.8	600	4 100	3/8-24 UNF	32 15	3.31 1.5	11.3 287	7.2	84 95	3/8

All models: Hose int. 3/8" (10 mm) - @90 PSI (@6.3 Bar)

Listed specifications are for reference only. Please check documents in each tool.

4" to 5"
Power capacity > 1.1 hp (810W)



12,000 RPM



CP3450-12AA5

UNIQUE LOW PROFILE ANGLE HEAD FOR VERSATILE USE

FEATURES AND BENEFITS

- Industrial grade durability up to 1,000 hours between maintenance intervals
- Streamlined orientable safety lever for operator comfort
- Steel housing with an insulating composite over-housing for optimal handling
- Low profile angle head for better ergonomics
- Constant lubrication bevel gear design



12,000 RPM



CP7545-B

POWERFUL AND DURABLE

FEATURES AND BENEFITS

- High durability thanks to its high quality bevel gears and governed motor
- High security with its robust steel keyless adjustable wheel rotative guard and its CP safety Lever
- Streamline composite handle (right or left) and composite grip for better operator comfort
- Rear exhaust (exhaust hose included)
- 360° swivel air inlet

CP3450-12AB5

Same features as CP3450-12AA5 with 5/8-11 spindle thread

CP7550-A

Same features as CP7545-B with M14 spindle & 5" wheel

See accessories page 118

MODEL	PART NUMBER	FREE SPEED	AUTO-BALANCER	POWER	MAX WHEEL CAPACITY	SPINDLE THREAD	AIR CONS. @LOAD	NET WEIGHT	LENGTH	VIBRATION LEVEL ISO 28927 (M/S2)	SOUND PRESS.	SOUND POWER	AIR INLET					
		rpm		hp	W	in.	mm	in.	cfm	l/s	lb	kg	in.	mm	a	ISO 15744 - dB(A)	in.	
CP7545-B	8941075452	12,000	No	1.1	840	4-1/2	115	5/8-11 UNC	40	18	3.53	1.6	10.63	270	7	85	96	1/4
CP7550-A	8941075503	12,000	No	1.1	840	5	125	M14x2	40	18	3.53	1.6	10.63	270	7	85	96	1/4
CP3450-12AC4	6151604010	12,000	No	1.1	810	4	100	3/8-24 UNF	36	17	3.13	1.42	9.07	230.5	6.5	93.8	104.8	3/8
CP3450-12AC45	6151604030	12,000	No	1.1	810	4-1/2	115	3/8-24 UNF	36	17	3.13	1.42	9.07	230.5	8.3	93.8	104.8	3/8
CP3450-12AA5	6151604040	12,000	No	1.1	810	5	125	M14x2	36	17	3.75	1.7	9.09	231	-	95	-	3/8
CP3450-12AB5	6151604050	12,000	No	1.1	810	5	125	5/8-11 UNC	36	17	3.75	1.7	9.09	231	8.5	95	106	3/8

All models: Hose int. 3/8" (10 mm) - @90 PSI (@6.3 Bar)

Listed specifications are for reference only. Please check documents in each tool.

Angle Grinders



CP3550 SERIES

4" to 5"

Power capacity < 1.5hp (1100W)

INDUSTRIAL TOUGH AND EASY TO HANDLE

Looking for high performance and ease of use, such as quick abrasive change and swivel rotary air inlet, the CP3550 is the ideal industrial match for your grinding and cutting applications.



FEATURES AND BENEFITS

- Industrial grade durability up to 1,000 hours between maintenance intervals
- Streamlined safety lever and 1.5 hp (1,100 W) governed motor for operator safety
- Steel housing with an insulating composite over-housing for operator comfort
- Spindle lock button for fast abrasive replacement reducing tool downtime
- Rotative Inlet swivel maintains tool operation and avoids air hose knots

See accessories page 118

MODEL	PART NUMBER	FREE SPEED	AUTO-BALANCER	POWER	MAX WHEEL CAPACITY	SPINDLE THREAD	AIR CONS. @LOAD	NET WEIGHT	LENGTH	VIBRATION LEVEL ISO 28927 (M/S2)	SOUND PRESS.	SOUND POWER	AIR INLET
		rpm		hp W	in. mm	in.	cfm l/s	lb kg	in. mm	a	ISO 15744 - dB(A)		in.
CP3550-100AB6	6151607800	10,000	No	1.5 1100	6 150	5/8-11 UNC	55 26	4.63 2.1	9.96 253	6	85	96	3/8
CP3550-120AA45	6151607760	12,000	No	1.5 1100	4-1/2 115	M14x2	55 26	4.19 1.9	9.92 252	7.5	84	95	3/8
CP3550-120AA5	6151607780	12,000	No	1.5 1100	5 125	M14x2	55 26	4.19 1.9	9.92 252	-	84	-	3/8
CP3550-120AB45	6151607770	12,000	No	1.5 1100	4-1/2 115	5/8-11 UNC	55 26	4.19 1.9	9.92 252	7.5	84	95	3/8
CP3550-120AB5	6151607790	12,000	No	1.5 1100	5 125	5/8-11 UNC	55 26	4.19 1.9	9.92 252	9.8	84	95	3/8
CP3550-120AC4	6151607750	12,000	No	1.5 1100	4 100	3/8-24 UNF	55 26	3.75 1.7	9.92 252	6	84	95	3/8

All models: Hose int. 3/8" (10 mm) - @90 PSI (@6.3 Bar)

Listed specifications are for reference only. Please check documents in each tool.

Angle Grinders



CP3650 SERIES



4-1/2" to 6"

Power capacity < 2.4hp (1800W)

**DURABLE
PRODUCTIVITY
IN THE
TOUGHEST
WORK
ENVIRONMENTS**

CP3650 now with 25% increased durability and superior ergonomics



FEATURES AND BENEFITS

- +25% improved robustness with an exceptional bevel gear life of 2500 hours
- Governed motor for better productivity and reduced vibration
- A more durable design with a protective rubber on angle head housing and a steel swiveling air inlet
- Spindle lock button for fast and easy abrasive disc change
- Improved ergonomics with an orientable vibration damping side handle and a swiveling air inlet

See accessories page 118

MODEL	PART NUMBER	FREE SPEED	AUTO-BALANCER	POWER	MAX WHEEL CAPACITY	SPINDLE THREAD	AIR CONS. @LOAD	NET WEIGHT	LENGTH	VIBRATION LEVEL ISO 28927 (M/S2)	SOUND PRESS.	SOUND POWER	AIR INLET
		rpm		hp W	in. mm	in.	cfm l/s	lb kg	in. mm	a	ISO 15744 - dB(A)		in.
CP3650-120AA5	6151607860	12,000	No	2.4 1800	5 125	M14	63 29.8	4.85 2.2	9.74 247.5	7.4	90	-	3/8
CP3650-120AA5V	6151607870	12,000	Yes	2.4 1800	5 125	M14	63 29.8	4.85 2.2	9.74 247.5	5.2	92	-	3/8
CP3650-120AA5V	6151607880	12,000	Yes	2.4 1800	5 125	Hexa	63 29.8	4.85 2.2	9.74 247.5	3.8	92	-	3/8
CP3650-100AB6	6151607890	10,000	No	2.3 1600	6 150	5/8-11 UNC	55 26	5.07 2.3	9.74 247.5	-	89	-	3/8
CP3650-120AB45	6151607840	12,000	No	2.4 1800	4-1/2 115	5/8-11 UNC	63 29.8	4.85 2.2	9.74 247.5	-	90	-	3/8
CP3650-120AB5V	6151607900	12,000	Yes	2.4 1800	5 125	5/8-11 UNC	63 29.4	4.85 2.2	9.74 247.5	8.6	103	93	3/8
CP3650-100AB6V	6151607910	10,000	Yes	2.3 1695	6 150	5/8-11 UNC	61 28.9	5.07 2.3	9.74 247.5	5.3	101	90	3/8
CP3650-120AB5	6151607850	12,000	No	2.4 1800	5 125	5/8-11 UNC	63 29.8	4.85 2.2	9.74 247.5	-	90	-	3/8

All models: Hose int. 3/8" (10 mm) - @90 PSI (@6.3 Bar)

Listed specifications are for reference only. Please check documents in each tool.

Angle Grinders



CP3650 SERIES

Main features and characteristics

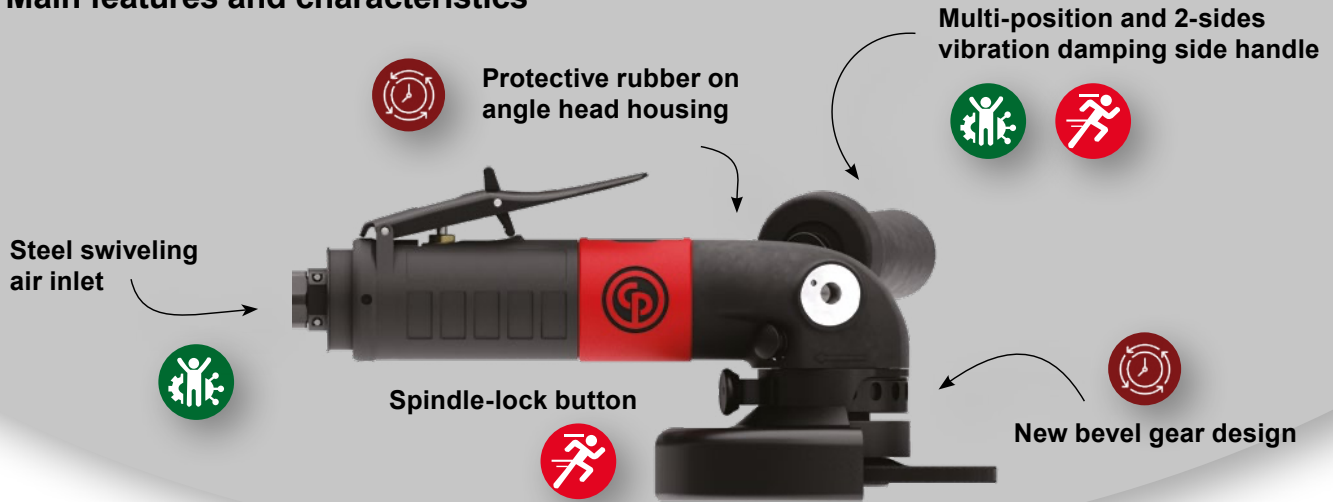

Durability

Easy adjustable guard by button pulling



New bevel gear design

Safety



Easy adjustable guard



Protective rubber



Ergonomics

Multi-position vibration damping side handle

Productivity



Steel swiveling air inlet



Rapid stop time



How to adjust safety guard



Exploring the CP3650 with our Product Marketing Manager



MODEL L H WIDTH WEIGHT

	mm	in.	mm	in.	mm	in.	kg	lbs
CP3650-120AB45	247.5	9.74	102	4	130	5.1	2.2	4.9
CP3650-120AB5	247.5	9.74	102	4	140	5.5	2.2	4.9
CP3650-120AA5	247.5	9.74	102	4	140	5.5	2.2	4.9
CP3650-120AA5V	247.5	9.74	102	4	140	5.5	2.2	4.9
CP3650-120AH5V	247.5	9.74	102	4	140	5.5	2.2	4.9
CP3650-100AB6	247.5	9.74	103	4	173	6.8	2.3	5.1

Angle Grinders 7"

Power capacity < 2.7hp (2000 W)



7,500 RPM



CP9123

ROBUST CONSTRUCTION

FEATURES AND BENEFITS

- 7" (180 mm) angle grinder with 5/8"-11 spindle thread
- Aluminum alloy housing for high durability
- Great operator comfort with its rubber handle grip



7,500 RPM



CP857

POWERFUL AND DURABLE FOR GENERAL MAINTENANCE

FEATURES AND BENEFITS

- High performance motor for high efficiency with its 1.3 hp (940 W)
- Helical bevel gear design & aluminum alloy housing for high durability
- 7" (180 mm) wheel capacity



8,500 RPM



CP3750-085AA7

THE BEST RATIO PRICE PERFORMANCE

FEATURES AND BENEFITS

- 2,2 HP / 1640 W air motor
- Vibration dampening side handle
- 1000 Hours bevel gear durability (Checking at 500 hours)
- One hand reinforced Swiveling Guard
- Swiveling air inlet



CP3750-085AB7

Same features as CP3750-085AA7 with 5/8 spindle thread

See accessories page 118

MODEL	PART NUMBER	FREE SPEED	AUTO-BALANCER	POWER		MAX WHEEL CAPACITY		SPINDLE THREAD	AIR CONS. @LOAD		NET WEIGHT		LENGTH		VIBRATION LEVEL ISO 28927 (M/S ²)	SOUND PRESS.	SOUND POWER	AIR INLET
		rpm		hp	W	in.	mm	in.	cfm	l/s	lb	kg	in.	mm	a	ISO 15744 - dB(A)		in.
CP9123	6151959123	7,500	No	1.1	850	7	180	5/8-11 UNC	24	11	7.5	3.4	13.39	340	4.3	93	104	3/8
CP857	T024387	7,500	No	1.3	940	7	180	5/8-11 UNC	24	11	6.17	2.8	13.15	334	4	102	113	3/8
CP3750-085AB7	6151607820	8,500	No	2.2	1638	7	180	5/8-11 UNC	74	35	6.39	2.9	12.36	314	7.6	89	100	1/2
CP3750-085AA7	6151607830	8,500	No	2.2	1638	7	180	M14x2	74	35	6.39	2.9	12.36	314	7.6	89	100	1/2

All models: Hose int. 3/8" (10 mm) - @90 PSI (@6.3 Bar)

Listed specifications are for reference only. Please check documents in each tool.

Angle Grinders



CP3850 SERIES

Angle Grinders 7" to 9"
Power capacity 2.8 hp (2100 W)

THE HIGHEST POWER-TO- WEIGHT RATIO IN ITS CLASS

The CP3850 series - 7" and 9" (180, 230 mm) angle grinders - has the highest power-to-weight ratio in its class. Designed for heavy-duty use in a harsh environment, it provides superior torque for maximum productivity.



FEATURES AND BENEFITS

- Highly durable spiral bevel gear reduces vibration and torque transmission stress, resulting in a 2,000 h maintenance interval
- Double streamlined safety lever facilitates single-handed engagement and helps reduce risk of accidental start up
- Ergonomic, multi-position (360°), anti-vibration side handle to keep the operator's wrist straight and comfortable
- 360° adjustable air exhaust with integrated muffler for a noise level limited to 84 dB(A)
- Debris magnet to collect debris and extend super durable spiral bevel gear

DIMENSIONS

MODEL	A		B		C	
	mm	in.	mm	in.	mm	in.
CP3850-...	134	340	4.8	122	1.14	29

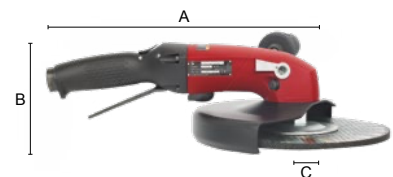

Angle Grinders 7" to 9" Power capacity 2.8 hp (2100W)



8,500 RPM



CP3850-85AB7VE



6,500 RPM



CP3850-65AH9VE



**maintenance
video**

See accessories page 118

ANSI	MODEL	PART NUMBER	FREE SPEED	AUTO-BALANCER	POWER		MAX WHEEL CAPACITY		SPINDLE THREAD	AIR CONS. @LOAD		NET WEIGHT		LENGTH		VIBRATION LEVEL ISO 28927 (M/S ²)	SOUND PRESS.	SOUND POWER	AIR INLET
			rpm		hp	W	in.	mm	in.	cfm	l/s	lb	kg	in.	mm	a	ISO 15744 - dB(A)		in.
	CP3850-60AB9V	6151607340	6,000	No	2.8	2100	9	230	5/8-11 UNC	80	38	7.05	3.2	13.39	340	6.8	93	104	1/2
	CP3850-85AB7V	6151607440	8,500	No	2.8	2100	7	180	5/8-11 UNC	76	36	6.61	3	13.39	340	5.7	87	98	1/2
	CP3850-77AB7V	6151704960	7,700	No	2.8	2100	7	180	5/8-11 UNC	67	32	6.61	3	13.39	340	5.3	84	95	1/2
	CP3850-85AB7VE	6151704920	8,500	Yes	2.8	2100	7	180	5/8-11 UNC	76	36	6.39	2.9	13.39	340	5.7	87	98	1/2
	CP3850-85AH7VE	6151704930	8,500	Yes	2.8	2100	7	180	HEXA	76	36	5.95	2.7	13.39	340	5.4	87	98	1/2
CE	CP3850-65AB9VE	6151704940	6,500	Yes	2.8	2100	9	230	5/8-11 UNC	80	38	5.95	2.7	13.39	340	-	93	-	1/2
	CP3850-65AH9VE	6151704950	6,500	Yes	2.8	2100	9	230	HEXA	80	38	6.39	2.9	13.39	340	5.4	93	104	1/2

All models: Hose int. 3/8" (10 mm) - @90 PSI (@6.3 Bar)

Listed specifications are for reference only. Please check documents in each tool.

Angle Grinders



CP3T30 SERIES



Angle Grinders 5 to 7"
Power capacity 3 hp - (2300 W)

DO MORE IN LESS TIME

Enter a new dimension in material removal CP3T30 Series Turbine Grinders



FEATURES AND BENEFITS

- High material removal for effective grinding
- Excellent power-to-weight ratio
- Compact design for hard-to-reach applications
- Autobalancer to minimize vibration for operator comfort
- Low noise level of only 78 dB(A) for a quieter workspace

See accessories page 118

MODEL	PART NUMBER	FREE SPEED	AUTO-BALANCER	POWER		MAX WHEEL CAPACITY		SPINDLE THREAD	AIR CONS. @LOAD		NET WEIGHT		LENGTH		VIBRATION LEVEL ISO 28927 (M/S2)	SOUND PRESS.	SOUND POWER	AIR INLET
		rpm		hp	W	in.	mm	in.	cfm	l/s	lb	kg	in.	mm	a	ISO 15744 - dB(A)		in.
CP3T30-085AH7V	6151607930	8,500	Yes	3.1	2300	7	180	HEXA	68	32	5.5	2.5	11.9	302	2.8	79	79	3/8
CP3T30-120AA5V	6151607940	12,000	Yes	3.1	2300	5	125	M14	68	32	5.3	2.4	11.9	302	3.5	79	79	3/8
CP3T30-120AH5V	6151607920	12,000	Yes	3.1	2300	5	125	HEXA	68	32	5.1	2.3	11.9	302	3.5	78	78	3/8

All models: Hose int. 3/8" (10 mm) - @90 PSI (@6.3 Bar)

Listed specifications are for reference only. Please check documents in each tool.

2300 W

(3 hp)*

Turbine engine for optimal material removal rate

2.3 kg

(5.1 lbs) only**

Light to hold, even at arm's length

86 mm

(3.4 in) height only

Ideal for use in restricted spaces

Featuring ease of use, safety and prevention of TMS risks



Spindle lock and guard positioning button

Quick guard adjustment with simple and secure abrasive replacement for optimum safety.



Lateral exhaust

Protects the operator's hands from cold exhaust air and reduces risk of material deformation.



Auto balancer and adjustable vibration handle

Optimal comfort over extended periods so your operator works safer for longer.

Dimensions

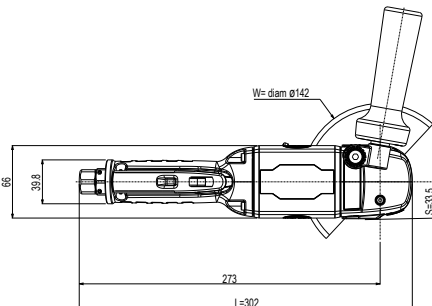
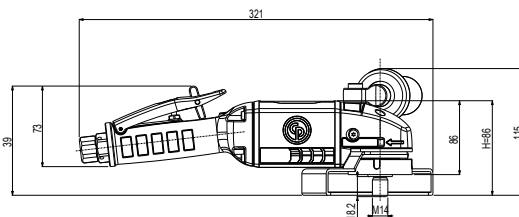

MODEL	L		H		WIDTH		SIDE TO CENTER	
	mm	in.	mm	in.	mm	in.	mm	in.
CP3T30-120AH5V	302	11.9	86	3.4	142	5.6	33.5	1.3
CP3T30-85AH7V	302	11.9	86	3.4	200	7.9	33.5	1.3
CP3T30-120AA5V	302	11.9	86	3.4	142	5.6	33.5	1.3

Remove 63%* more material than a standard vane grinder during the same period of time



Air efficiency kit - Filter regulator

PN 615 450 1105

includes 1/2" BSP,
Regulator adjusting knob
5 µm Filter,
Diaphragm-type pressure valve

Key Benefits

- Enhances tool performance for consistent and efficient operation
- Extends tool lifespan by preventing dust and water contamination
- Quick & easy installation for minimal downtime

Compatible with BSP and NPT system

* Results are based on Chicago Pneumatic tests laboratory

Vertical Grinders



CP3330 SERIES

Vertical Grinders 6" to 9"
Power capacity 3.7hp (2800W)

BEST IN CLASS PRODUCTIVITY, OPTIMAL SAFETY

A Best-in-class power for material removal twice as fast as competitors. The CP3330 vertical grinder from 6" to 9" (150 to 230 mm) is suitable for milling, deburring, cutting, finishing, and cleaning welds in harsh environments.



See accessories page 118

CE	ANSI	MODEL	PART NUMBER	FREE SPEED	AUTO-BALANCER	POWER		MAX WHEEL CAPACITY		SPINDLE THREAD	AIR CONS. @LOAD		NET WEIGHT		LENGTH	VIBRATION LEVEL ISO 28927 (M/S2)	SOUND PRESS.	SOUND POWER	AIR INLET	
				rpm		hp	W	in.	mm	in.	cfm	l/s	lb	kg	in.	mm	a	ISO 15744 - dB(A)		in.
		CP3330-SALAVET	6151609210	6000	No	3.75	2800	6	150	5/8-11 UNC	69	33	10.1	4.6	9.84	250	3.5	78	-	1/2
		CP3330-SALAVAD	6151609220	8500	No	3.75	2800	7	180	5/8-11 UNC	82	39	10.4	4.75	9.84	250	5.2	91	102	1/2
		CP3330-SALAVEL	6151609230	6000	No	3.75	2800	9	230	5/8-11 UNC	69	33	11.2	5.1	9.84	250	4.4	95	106	1/2
		CP3330-SALAVADE	6151609250	8500	No	3.75	2800	7	180	5/8-11 UNC	82	39	10.2	4.65	9.84	250	5.2	91	102	1/2
		CP3330-SALAVELE	6151609260	6000	No	3.75	2800	9	230	5/8-11 UNC	69	33	11	5	9.84	250	4.4	95	106	1/2

All models: Hose int. 3/8" (10 mm) - @90 PSI (@6.3 Bar)

Listed specifications are for reference only. Please check documents in each tool.

Vertical Grinders 6" to 9" Power capacity 3.7 hp (2800W)



6000 RPM



CP3340-SALAVEL



8500 RPM



CP3340-SALAVADE

FEATURES AND BENEFITS

- Highest durability in demanding applications with up to 2,000 hours maintenance intervals
- Governed motor - 4.5 hp (3,400 W) - ensures operator safety while maintaining abrasive speed under operator load
- Overspeed shut-off device, avoids abrasive bursts in case of accidental air pressure variations
- Robust aluminum housing and high resistance protective guard for long-term durability
- Streamlined safety lever allows easy tool operation while wearing heavy gloves

See accessories page 118

ANSI	MODEL	PART NUMBER	FREE SPEED	AUTO-BALANCER	POWER		MAX WHEEL CAPACITY		SPINDLE THREAD	AIR CONS. @LOAD		NET WEIGHT		LENGTH	VIBRATION LEVEL ISO 28927 (M/S ²)	SOUND PRESS.	SOUND POWER	AIR INLET	
			rpm		hp	W	in.	mm	in.	cfm	l/s	lb	kg	in.	mm	a	ISO 15744 - dB(A)	in.	
	CP3340-SALAVAD	6151609280	8500	No	4.56	3400	7	180	5/8-11 UNC	110	52	12.3	5.6	9.84	250	4.9	100	111	1/2
	CP3340-SALAVEL	6151609290	6000	No	4.56	3400	9	230	5/8-11 UNC	95	45	13.1	5.95	9.84	250	< 2.5	95	106	1/2
CE	CP3340-SALAVET	6151609270	6000	No	4.56	3400	6	150	5/8-11 UNC	95	45	12.1	5.5	9.84	250	3.6	95	106	1/2
	CP3340-SALAVADE	6151609310	8500	No	4.56	3400	7	180	5/8-11 UNC	110	52	12.1	5.5	9.84	250	4.9	100	111	1/2
	CP3340-SALAVELE	6151609320	6000	No	4.56	3400	9	230	5/8-11 UNC	95	45	12.9	5.85	9.84	250	< 2.5	95	106	1/2

All models: Hose int. 3/8" (10 mm) - @90 PSI (@6.3 Bar)

Listed specifications are for reference only. Please check documents in each tool.

Vertical Grinders



CP3349 SERIES

Vertical Grinders 6" to 9"
Power capacity 4 hp (3000W)

ULTIMATE PERFORMANCE IN HEAVY APPLICATIONS

Ultimate performance in heavy applications such as foundries with this vertical grinder. The CP3349 is highly robust and durable thanks to its integrated lubrication tank.



maintenance video



See accessories page 118

CE MARKET

MODEL	PART NUMBER	FREE SPEED	AUTO-BALANCER	POWER	MAX WHEEL CAPACITY	SPINDLE THREAD	AIR CONS. @LOAD	NET WEIGHT	LENGTH	VIBRATION LEVEL ISO 28927 (M/S2)	SOUND PRESS.	SOUND POWER	AIR INLET
		rpm		hp W	in. mm	in.	cfm l/s	lb kg	in. mm	a	ISO 15744 - dB(A)		in.
CP3349-SALAVADE	6151609110	7700	No	4.02 3000	7 180	5/8-11 UNC	97 46	9.26 4.2	11.02 280	4.6	88	99	1/2
CP3349-SALAVELE	6151609130	6500	No	4.02 3000	9 230	5/8-11 UNC	93 44	9.7 4.4	11.02 280	4	87	98	1/2
CP3349-SALAVETE	6151609150	6000	No	4.02 3000	6 150	5/8-11 UNC	91 43	9.7 4.4	11.02 280	<2.5	84	95	1/2

All models: Hose int. 3/8" (10 mm) - @90 PSI (@6.3 Bar)

Listed specifications are for reference only. Please check documents in each tool.

Vertical Grinders 6" to 9" Power capacity 4 hp (3000W)



6000 RPM



CP3349-SALAVET



6000 RPM



CP3349-SALAVEL

FEATURES AND BENEFITS

- Highest durability in demanding applications, up to 2,000 hours maintenance intervals
- Double ergonomic action safety lever facilitates single-handed engagement and helps reduce risk of accidental start up
- An ergonomic handle to promote a good operating position by keeping the operator's wrist straight
- Built-in lubricant tank for constant lubrication, reducing failure and increasing tool lifetime
- Reinforced rubber grip side handle provides a steady grip, increasing operator grinding control

See accessories page 118

ANSI MARKET

MODEL	PART NUMBER	FREE SPEED	AUTO-BALANCER	POWER		MAX WHEEL CAPACITY		SPINDLE THREAD	AIR CONS. @LOAD		NET WEIGHT		LENGTH		VIBRATION LEVEL ISO 28927 (M/S ²)	SOUND PRESS.	SOUND POWER	AIR INLET
		rpm		hp	W	in.	mm	in.	cfm	l/s	lb	kg	in.	mm	a	ISO 15744 - dB(A)		in.
CP3349-SALAVEL	6151609070	6000	No	4.02	3000	9	230	5/8-11 UNC	93	44	9.7	4.4	11.02	280	-	87	98	1/2
CP3349-SALAVET	6151609080	6000	No	4.02	3000	6	150	5/8-11 UNC	91	43	9.7	4.4	11.02	280	<2.5	84	95	1/2

All models: Hose int. 3/8" (10 mm) - @90 PSI (@6.3 Bar)

Listed specifications are for reference only. Please check documents in each tool.

Angle Grinders Accessories

ACCESSORIES INCLUDED

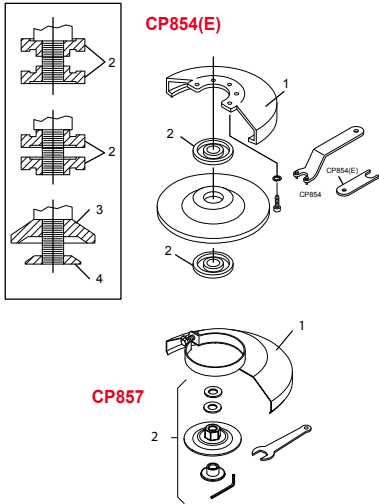

TOOLS MODEL	ITEM	ACCESSORY'S DESCRIPTION	ACCESSORY'S PART N°
CP7500D		2" Grinding wheel 60 Grit (5 PC) 20,000 (max speed)	8940162768
		2" Grinding wheel 80 Grit (5 PC) 20,000 (max speed)	8940162769
		2" Grinding wheel 120 Grit (5 PC) 20,000 (max speed)	8940162770
		Spanner	8940162759
		Nuts	8940162765
		2" Cutting wheel 20,000 (max speed)	8940164490
CP7550-A/-B/-C		5" (125 mm) Disc Guard	8940173446
		Flange kit for 3/8"-24 UNF (Flange+nut)	8940173437
		Flange kit for 5/8"-11 UNC (Flange+nut+screw)	8940173438
		Flange kit for M14 (Flange+nut+screw)	8950251317
		Tool kit (Pin wrench+spanner+key)	8940173513
		Side Handle	2050524063
CP854		Exhaust hose kit	8940173439
	1	4" (100 mm) Disc Guard	C136898
	2	Nut	C138512
	3	Wheel adapter	C128495
	4	Wheel retainer, nut	C050588
		Wrench stop spanner	C136927
		Wrench wheel spanner	C136926
		Wrench 5/8" open end	C139702
		Side handle	C136901
	CP854E	1	5" (125 mm) Disc Guard
2		Nut	C138512
		Wheel adapter	KF141861
CP857	1	7" (180 mm) Disc Guard	C139081
		Wrench-spindle	C141027
	2	Adapter	C087920
CP9120CR CP7540C		4" (100 mm) Disc Guard	2050534003
		Flange kit for 3/8"-24 UNF (Flange + nut)	8940173435
		Tool kit (Pin wrench + 2 spanners)	8940173440
		Side Handle	2050524063
		Exhaust hose kit for CP7540C	8940173439
CP7540-CN		4" (100 mm) Disc Guard	2050534003
		Flange kit for 3/8"-24 UNF (Flange+nut+2 nuts)	8940173435
		Tool kit (Pin wrench + 2 spanners)	8940173440
		Side Handle	2050524063
		Exhaust hose kit for CP7540CN	8940173439
CP9121AR/BR/CR		5" (125 mm) Disc Guard	2050534023
		Flange kit for 3/8"-24 UNF (Flange+nut)	8940173437
		Flange kit for 5/8"-11 UNC (Flange+nut)	8940173438
		Flange kit for M14 (Flange+nut)	8950251317
		Tool kit (Pin wrench+spanner)	8940173513
CP9122-BR/CR CP7545-B/C		Side Handle	2050524063
		4.5" (115 mm) Disc Guard	2050534013
		Flange kit for 3/8"-24 UNF (Flange+nut)	8940173437
		Flange kit for 5/8"-11 UNC (Flange+nut+screw*)	8940173438
		Tool kit (Pin wrench+spanner+key*)	8940173513
CP9123		Side Handle	2050524063
		Exhaust hose kit for CP7545 *not used on CP9122	8940173439
		Disc Guard	2050500973
		Flange	2050500963
		Flange Nut	2050500983
		Spanner	2050501193
		Hex. Key	2050501213
		Wheel retainer, nut	KF142108
		Wrench stop spanner	C136927
	Wrench spanner	KF141865	
	Side handle	C136901	

Angle Grinders Accessories

ACCESSORIES INCLUDED

CP3040...



For 3/8" & 5/8" hole disc

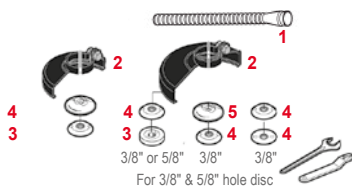

For 3/8" & 5/8" hole disc



For 7/8" hole disc



For 7/8" hole disc



For 7/8" hole disc



For 5/8" hole disc



TOOLS MODEL	ITEM	ACCESSORY'S DESCRIPTION	ACCESSORY'S PART N°
CP3040-GABTIM CP3040-GASTIM	1	ø 4" (100 mm) Disc Guard	2050545213
	2	Rear Flange 3/8"	2050544263
	3	Rear Flange 5/8"	2050552633
	4	Flange nut 3/8"	2050544273
	5	Flange nut 5/8"	2050552643
		Spanner Wrench (for 3/8" flange)	2050544293
		Pin Wrench (for 3/8" flange)	2050544283
		Spanner Wrench (for 5/8" flange)	2050544303
		Spanner Wrench (for 5/8" flange)	2050552953
		Pin Wrench (for 5/8" flange)	2050552943
CP3019-..A3 CP3019-..A4	1	Exhaust hose L= 31" (0.8 m)	6158751060
	2	3" (76 mm) Disc Guard (A3)	6155041550
	3	4" (100 mm) Disc Guard (A4)	6155041600
	4	Flange	6156065150
	5	Flange	6155020640
	Rear flange	6155031440	
	Pin Wrench	6158020080	
	Flat Wrench 7/16" (11 mm)	6158010030	
CP3450-12AA5	1	4.5" (115 mm) Disc Guard	6155042030
	2	Rear Flange 3/8"	2050533943
	3	Flange nut 3/8"	2050533973
	4	Safety Screw	6156140900
		Flat Wrench	CA144807
		Pin Wrench	2050486673
		Hex wrench	8951011464
CP3450-12AC45	1	5" (125 mm) Disc Guard	6155042030
	2	Rear Flange 5/8"	2050533943
	3	Flange nut 5/8"	2050533973
	4	Safety Screw	6156140900
		Flat Wrench	CA144807
		Pin Wrench	2050486673
	Hex wrench	8951011464	
CP3450-12AB5	1	4" (100 mm) Disc Guard	6155041880
	2	Flange (2)	8940173436
	3	Flat Wrench	CA144807
	4	Pin Wrench	2050485003
CP3450 -12AC4 CP3450-12ACR4	1	4" (100 mm) Disc Guard	6155041880
	2	Flange (2)	8940173436
		Flat Wrench	CA144807
		Pin Wrench	2050485003
CP3450-..		Side handle	2050524063
		Exhaust kit	2050541503

Angle Grinders Accessories

ACCESSORIES INCLUDED

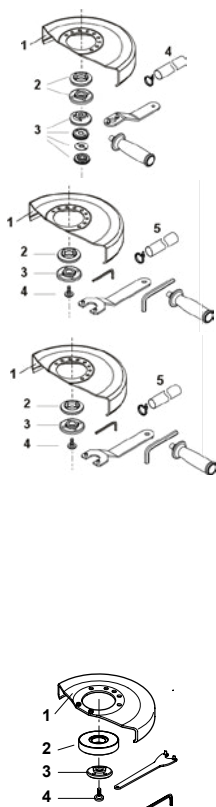

TOOLS MODEL	ITEM	ACCESSORY'S DESCRIPTION	ACCESSORY'S PART N°
CP3550-120AC4	1	Wheel guard 4"	6155042360
	2,3,4	Flange 3/8" Kit	6153995200
	5	Exhaust Hose Kit	6153995230
		Side Handle	2050524063
		Tool Kit 4"	8940173440
CP3550-120AA45 CP3550-120AA5	1	Guard 4,5"	6155042370
	1	Guard 5"	6155042380
	2,3,4	Flange M14 Kit	8950251317
	5	Exhaust Hose Kit	6153995230
		Side Handle	2050524063
CP3550-120AB5 CP3550-120AB45		Tool Kit 4,5" 5" & 6"	6153995240
	1	Guard 4,5"	6155042370
	1	Guard 5"	6155042380
	2,3,4	Flange 5/8" Kit	8940173438
	5	Exhaust Hose Kit	6153995230
CP3650-100AB6 CP3650-100AB6V		Side Handle	2050524063
		Tool Kit 4,5" 5" & 6"	6153995240
	1	6" Wheel guard kit	6154503305
	2,3,4	Flange locking kit for 5/8"-11 UNC	6154503485
		Pin wrench	6154503285
CP3650-120AA5 CP3650-120AA5V		HEX KEY - 5/32"	6158020740
	1	5" Wheel guard kit	6154503075
	2,3,4	Flange locking kit for M14x2	6154503125
		Pin wrench	6154503285
		HEX KEY - 5/32"	6158020740
CP3650-120AB45	1	4-1/2" Wheel guard kit	6154503295
	2,3,4	Flange locking kit for 5/8"-11 UNC	6154503485
		Pin wrench	6154503285
		HEX KEY - 5/32"	6158020740
	1	5" Wheel guard kit	6154503075
CP3650-120AB5 CP3650-120AB5V	2,3,4	Flange locking kit for 5/8"-11 UNC	6154503485
		Pin wrench	6154503285
		HEX KEY - 5/32"	6158020740
		5" Wheel guard kit	6154503075
	CP3650-120AH5V		Wheel retention kit H
		HEXAGON WRENCH 6MM A/F	6158020560

Angle & Vertical Grinders Accessories

ACCESSORIES INCLUDED

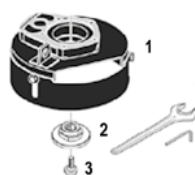
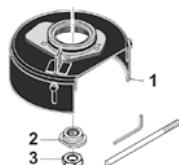
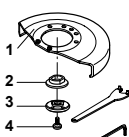
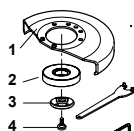
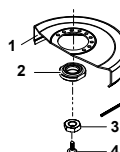
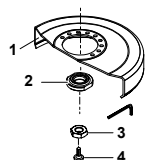

TOOL'S MODEL	ITEM	ACCESSORY'S DESCRIPTION	ACCESSORY'S PART N°	
CP3850-60AB9V	1	Guard 9" US kit	2050559613	
	2	Rear flange	6155031530	
	3	Nut 5/8" UNC27	6156080490	
	4	Safety screw	6156140340	
			Hex. key 6 mm	6158020560
CP3850-77AB7V CP3850-85AB7V	1	Guard 7"(180 mm) US kit	6155042135	
	2	Rear flange	6155031530	
	3	Nut 5/8" UNC27	6156080490	
	4	Whell adaptor	C087920	
			Hex. key 6 mm	6158020560
			NIPPLE 1/2 BSP X 16DIA	6157040140
CP3850-65AB9VE CP3850-85AB7VE		SPANNER FLAT 27 A/F(SPECIAL)	6158010770	
	1	9" (230 mm) Disc Guard (CP3850-65AB9VE)	6155042125	
	1	7" (180 mm) Disc Guard (CP3850-85AB7VE)	6155042115	
	2	Autobalancer (CP3850-65AB9VE)	6159901810	
	3	Front Flange	6155020670	
	4	Safety screw	6156140760	
			Pin wrench 1-3/8" (35 mm)	6158020100
			ALLEN KEY 1/4 A/F HEX	69773
			NIPPLE 1/2 BSP X 16DIA	6157040140
	CP3850-65AH9VE CP3850-85AH7VE	1	9" (230 mm) Disc Guard (CP3850-65AH9VE)	6155042125
1		7" (180 mm) Disc Guard (CP3850-85AH7VE)	6155042115	
2		Auto balancer (AH7VE)	6159901940	
3		Rear Flange	6155031640	
4		Front Flange	6155020850	
			Pin wrench 1-3/8" (35 mm)	6158020100
CP3349-SALAVELE		NIPPLE 1/2 BSP X 16DIA	6157040140	
	1	9" (230 mm) Disc Guard	6155041830	
	2	Rear Flange	6155031030	
	4	Nut	6155421040	
	5	Locknut	6156140340	
			Pin wrench 1-3/8" (35 mm)	6158020100
CP3349-SALAVET		Flat wrench 1-1/16" (27 mm)	6158010770	
			Hex key 6 mm	6158020560
	1	6" (150 mm) Disc Guard	6155041780	
	2	Rear Flange	6155031500	
	3	Nut	6156080490	
			Lever	6155952020
CP3349-SALAVADE		Hex key 6 mm	6158020610	
	1	7" (180 mm) Disc Guard	6155041820	
	2	Rear Flange	6155031030	
	3	Nut	6155421040	
	4	Locknut	6156140340	
			Pin wrench 1-3/8" (35 mm)	6158020100
CP3349-SALAVETE		Flat wrench 1-1/16" (27 mm)	6158010770	
			Hex key 6 mm	6158020560
	1	6" (150 mm) Disc Guard	6155041810	
	2	Rear Flange	6155031160	
		Locknut	6156140340	
		Flat wrench 1-1/16" (27 mm)	6158010770	
		Hex key 6 mm	6158020560	

Vertical Grinders Accessories

ACCESSORIES INCLUDED

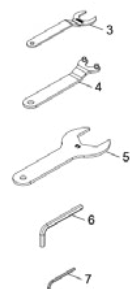
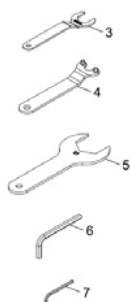
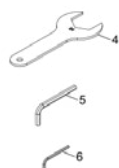
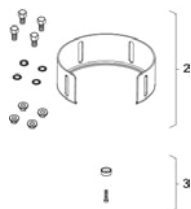

TOOLS MODEL	ITEM	ACCESSORY'S DESCRIPTION	ACCESSORY'S PART N°
CP3330/CP3340 SALAVET	2	6" Guard top kit	6155042400
	2	6" Guard bottom kit	6155042410
	3	Type 6 and 11 wheel retention kit	6155483070
	4	Spanner - 51 mm	6158020720
	5	Hex key - 5/16"	6158020730
	6	Hex key - 5/32"	6158020740

TOOLS MODEL	ITEM	ACCESSORY'S DESCRIPTION	ACCESSORY'S PART N°
CP3330/CP3340 SALAVAD & SALAVADE	1	7" Guard kit	6155042340
	2	Type 27 and 42 wheel retention kit	6155483080
	3	Spanner - 24 mm	6158020750
	4	Pin wrench - 32 mm / ø3	8950290147
	5	Spanner - 51 mm	6158020720
	6	Hex key - 5/16"	6158020730
	7	Hex key - 5/32"	6158020740

TOOLS MODEL	ITEM	ACCESSORY'S DESCRIPTION	ACCESSORY'S PART N°
CP3330/CP3340 SALAVEL & SALAVELE	1	9" Guard kit	6155042350
	2	Type 27 and 42 wheel retention kit	6155483080
	3	Spanner - 24 mm	6158020750
	4	Pin wrench - 32 mm / ø3	8950290147
	5	Spanner - 51 mm	6158020720
	6	Hex key - 5/16"	6158020730
	7	Hex key - 5/32"	6158020740

Angle & Vertical Grinders Accessories

OPTIONAL ACCESSORIES

CP3450 ACCESSORIES



ITEM	ACCESSORY'S DESCRIPTION	ACCESSORY'S PART N°
1	Vibration damping side handle	6155760780
2	Exhaust hose adapter	6157301870
3	Overhose	2050547523

CP3650 ACCESSORIES



ITEM	ACCESSORY'S DESCRIPTION	ACCESSORY'S PART N°
1	Silencer kit	6153961660
2	Clip-on silencer	6153969570
3	Exhaust hose	6158751130
4	Dust extraction kit for 5" cutting wheel	6158136210
5	Hex key - 5/16"	6158020730
6	Hex key - 5/32"	6158020740

AUTO BALANCER



TOOL'S MODEL	ACCESSORY'S DESCRIPTION	ACCESSORY'S PART N°
CP3349-SALAVADE/ CP3349-SALAVELE	Auto Balancer	6155031460

TUNE UP KIT



TOOL'S MODEL	TUNE UP KIT
CP3040	2050545223
CP3109-13 AC/A4	2050541673
CP3109-13A4ES	2050541663
CP3330	6153994130
CP3340	6153994120
CP3450-..	6153973030
CP3550-...	6153995300
CP3650 Series	6154503145
CP75.. Serie	8940173442
CP854	C138089
CP9120CR	2050504823
CP9123	2050503733
CP9121/CP9122	2050504823



SILENCERS/EXHAUST HOSE

TOOL'S MODEL	ACCESSORY'S DESCRIPTION	ACCESSORY'S PART N°
CP3019-..	Silencer Kit	6153961010
	Clippable Silencer	6153961240
CP3109-..	Silencer Kit	6158751130
CP3450-..	Silencer Kit	6155740760
CP3109-..	Exhaust Hose L=30"(0,75 m)	6158751160

PAD



TOOL'S MODEL	ACCESSORY'S DESCRIPTION	ACCESSORY'S PART N°
CP3450-12AC4/ CP3450-12ACR4/ CP3450-12AC45	Sanding Pad 4" Arbor 3/8-24	6159901900
CP3450-12AA5/ CP3450-12AB5	Sanding Pad 5" Arbor 5/8-11 & M14	6159901910

Angle Grinders Accessories & Spares

OPTIONAL ACCESSORIES

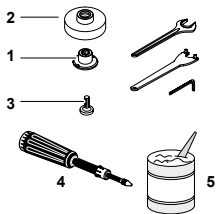

TOOL'S MODEL	ITEM	ACCESSORY'S DESCRIPTION	ACCESSORY'S PART N°
CP3850-77ABVE CP3850-85ABVE	1	Nut	6155421040
	2	Autobalancer	6155031460
	3	Safety Screw	6156140340
	4	Grease Gun	6159901490
	5	Grease for bevel gear (1kg)	6159901480

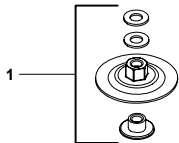
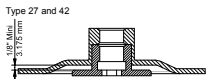

TOOL'S MODEL	ITEM	ACCESSORY'S DESCRIPTION	ACCESSORY'S PART N°
CP3850-77AB7V CP3850-85AB7V CP3850-60AB9V	1	Wheel adapter	C087920

Type 27 - 41 and 42

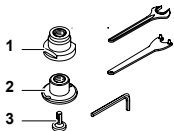
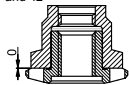

TOOL'S MODEL	ITEM	ACCESSORY'S DESCRIPTION	ACCESSORY'S PART N°
CP3850-77AB7V CP3850-85AB7V CP3850-60AB9V	1	Rear flange	6155031030
	2	Nut	6155421040
	3	Safety Screw	6156140340
		Pin spanner 1-3/8" (35 mm)	6158020100
		Flat spanner	6158010770
		Hexagon wrench 6 mm	6158020560



EFFICIENCY KIT

The Chicago Pneumatic **Efficiency Kit**, equipped with a 3/4" ID Filter-Regulator unit, is designed to keep your tools running at their best. It maintains consistent air pressure for your pneumatic tools and enhances air quality by effectively filtering out moisture and dust, safeguarding your equipment and extending its lifespan.



ACCESSORY'S DESCRIPTION	ACCESSORY'S PART N°
Adaptor 3/4 BSP/ NPT (only for North America) Ball valve F/F 3/4 BSP Filter/Regulator 3/4" BSP Wall Mounting for 3/4" Filter-Regulator (SET OF 2) Hose Effi Max Ø 5/8" - 3 m Hose Whip Effi Max Ø 1/2" - 0,6 m	6158136820